

SEALED BID SPECIFICATIONS AND CONTRACT DOCUMENTS



RODEO ARENA INTERLOCAL COOPERATIVE

PROJECT: SB 2025-4

WILL ROGERS STAMPEDE ARENA VIP MEZZANINE

December 13th, 2025

*Please return bid documents to:
Finance Office
104 S. Muskogee
Claremore, Ok 74017*

CONSTRUCTION CONTRACT DOCUMENTS INDEX

SECTION	PAGE#
1. Invitation to Bid	3
2. Information for Bidders	4
3. Bid Proposal	6
4. Bidder's Contact Information	7
5. Bid Schedule	8
6. Experience Questionnaire	9
7. Superintendent Questionnaire	12
8. Business Relationships Affidavit	13
9. Non-Collusion Affidavit	14
10. Claim or Invoice Affidavit	15
11. Bid Bond	16
12. Notice of Award	18
13. Contract	19
14. General Conditions	21
15. Supplemental General Conditions	35
16. Performance Bond	39
17. Statutory (Payment) Bond	40
18. Maintenance Bond	41
19. Insurance Requirements	42
20. Attorney's Certificate of Approval of Contract and Bonds for Rodeo Arena Interlocal Cooperative	43
SEPARATE DOCUMENTS	
Will Rogers Stampeded Arena VIP Mezzanine 2025 Plans – 42 PAGES	

SB-2025-4

Advertised in the Claremore Progress December 13th, 2025 & December 20th, 2025.

INVITATION TO BID

WILL ROGERS STAMPEDE ARENA VIP MEZZANINE

Notice is hereby given that the Rodeo Arena Interlocal Cooperative will receive SEALED BIDS # SB-2025-4 at the office of the City of Claremore Finance Department at 104 South Muskogee Avenue, Claremore, OK 74017 until **2:00 pm, on the 14th day of January, 2026**, at which time bids will be publicly opened and read aloud in the City Hall Council Chambers.

Contract bid documents, specifications and plans may be viewed at the CITY OF CLAREMORE, ENGINEERING DEPARTMENT, 724 RAMM RD, CLAREMORE, OKLAHOMA 74017. For all questions relating to the plans and specifications, contact Garrett L. Ball, City Engineer at 918-341-0457, Ext 209 or Levi Hix, Assistant City Engineer at 918-341-0457 Ext. 217.

Digital copies of the contract bid documents, specifications and plans may be obtained at: <https://claremore.com/bids/> for no fee.

Hard copies may be obtained at the CITY OF CLAREMORE, PLANNING & DEVELOPMENT DEPARTMENT, 724 RAMM RD, CLAREMORE, OKLAHOMA 74017 upon payment of a non-refundable fee of \$50.00. To view bidding documents or to obtain copies contact Joy Young at (918) 341-0457, Ext 200 or Joy.Young@claremore.com.

Bids filed with the City of Claremore Finance Department shall be publicly opened at the time stated above and considered by the Rodeo Arena Interlocal Cooperative in a Special Meeting to be determined following the bid opening. Bids received more than ninety-six (96) hours, excluding Saturdays, Sundays and holidays before the time set for opening of bids, as well as bids received after the time set for opening of bids, will not be considered and will be returned unopened.

Bidders are notified that this Project is governed by the requirements of the Public Competitive Bidding Act of 1974. A cashier's check, a certified check or a surety bond for five percent (5%) of the bid shall accompany the sealed proposal of each bidder. All paperwork in the bids submitted shall be complete. Any incomplete paperwork may be considered an unresponsive bid. Bidders agree to commence Work within ten (10) calendar days after issuance of a Notice to Proceed, and to complete the same within 110 CALENDAR DAYS. The Rodeo Arena Interlocal Cooperative reserves the right to reject any or all bids and to waive minor irregularities. Contractor must have extensive experience with concrete and steel structure construction.

A **NON-MANDATORY PRE-BID CONFERENCE** will be held at **2:00 pm on January 5th, 2026** at the Claremore City Hall City Council Chambers, 104 South Muskogee Ave, Claremore, OK. **ALL PROSPECTIVE BIDDERS ARE STRONGLY ENCOURAGED TO ATTEND THIS MEETING.**

INFORMATION FOR BIDDERS

Bids will be received by the RODEO ARENA INTERLOCAL COOPERATIVE (Herein called the "Owner".) at CITY OF CLAREMORE, FINANCE DEPARTMENT, 104 SOUTH MUSKOGEE, CLAREMORE, OKLAHOMA 74017 until 2:00 p.m., on the 14th day of JANUARY, 2026.

A public bid opening will take place in THE CITY OF CLAREMORE COUNCIL CHAMBERS at 2:00 p.m. on that date

Each bid submitted by mail must be submitted in a sealed envelope addressed to CITY OF CLAREMORE, ATTN.: GRADY LEMONS, FINANCE DEPARTMENT 104 S. MUSKOGEE AVE, CLAREMORE, OKLAHOMA 74017

ALL PROSPECTIVE BIDDERS ARE ENCOURAGED TO ATTEND A NON-MANDATORY PRE-BID CONFERENCE ON JANUARY 5TH AT 2:00 P.M. AT THE CLAREMORE CITY COUNCIL CHAMBERS AT 104 S. MUSKOGEE AVE, CLAREMORE, OK 74017.

Each sealed envelope containing a bid must be plainly marked on the outside as "SB-2025-4" and the envelope should bear on the outside the bidder's name, address and license number, if applicable, and the name of the Project for which the bid is submitted. If forwarded by mail, the sealed envelope containing the bid must be enclosed in another envelope addressed to FINANCE DEPARTMENT at 104 S. Muskogee Ave, Claremore, OK 74017

All bids must be made on the required bid form. All blank spaces for bid prices must be filled in, in ink or typewritten, and the bid form must be fully completed and executed when submitted. One copy of the bid form and required documentation shall be submitted.

The Owner may waive any informalities or minor defects or reject any and all bids. Any bid may be withdrawn prior to the above-scheduled time for the opening of bids or authorized postponement thereof. Any bid received after the time and date specified shall not be considered. No bidder may withdraw a bid within 30 days after the actual date of the opening thereof. Should there be reasons why the contract cannot be awarded within the specified period; the time may be extended by mutual agreement between the Owner and the bidders.

The Contract Documents contain the provisions required for the construction of the Project. Information obtained from an officer, agent or employee of the Owner or any other person shall not affect the risks or obligations assumed by the contractor or relieve the contractor from fulfilling any of the conditions of this contract.

Each bid must be accompanied by a bid bond payable to the Owner for five percent of the total amount of the bid. As soon as the bid prices have been compared, the Owner will return the bonds of all except the three lowest responsible bidders. When the agreement is executed, the bonds of the two remaining unsuccessful bidders will be returned. The bid bond of the successful bidder will be retained until the payment bond and performance bond and/or statutory bond have been executed and approved, after which it will be returned. A certified check may be used in lieu of the bid bond.

A performance bond, a maintenance bond and a payment/statutory bond, each in the amount of 100 percent of the Contract Price and each with a corporate surety approved by the Owner, will be required for the faithful performance of the contract.

Attorneys-in-fact who sign bid bonds, payment bonds and performance bonds must file with each bond a certified copy of their Power of Attorney bearing the effective date.

The party to whom the contract is awarded will be required to execute the agreement and deliver required insurance certificates within fifteen (15) calendar days from the date when Notice of Contract Award is delivered to the bidder. The Notice of Contract Award shall be accompanied by the necessary agreement. In case of failure of the bidder to execute the agreement, the Owner may consider the bidder in default, in which

case the bid bond accompanying the proposal shall become the property of the Owner. The Owner shall sign the agreement and return to such party an executed duplicate of the agreement.

The Owner may make such investigations as deemed necessary to determine the ability of the bidder to perform the Work and the bidder shall furnish to the Owner all such information and data for this purpose as the Owner may request. The Owner reserves the right to reject any bid if the evidence submitted by or investigation of such bidder fails to satisfy the Owner that such bidder is properly qualified to carry out the obligations of the agreement and to complete the Work contemplated therein.

A conditional or qualified bid will not be accepted.

Award will be made to the lowest responsible bidder. Determination of the lowest bid shall be based on a theoretical work order used to evaluate the unit prices.

All applicable laws, ordinances and the rules and regulations of all authorities having jurisdiction over construction of the Project shall apply to the contract throughout.

Each bidder is responsible for inspecting the site and for reading and being thoroughly familiar with the Contract Documents. The failure or omission of any bidder to do any of the foregoing shall in no way relieve any bidder from any obligation with respect to its bid.

The low bidder shall supply the names and addresses of major material suppliers and Subcontractors when required to do so by the Owner.

SPECIAL NOTE TO BIDDERS:

As a part of the bid on this Project, the successful bidder will be required to meet all requirements of the Underground Facilities Damage Prevention Act when engaged in Work within the public right-of-way in the same manner as in private right-of-way.

SPECIFICATIONS & SCOPE OF WORK:

This project will be bid as a lump-sum contract inclusive of all work required to provide and construct a turn key mezzanine structure as shown in the plans. All demolition work, site work, construction and cleanup shall be included and considered incidental if not specifically listed in the construction documents.

The contractor shall be responsible for providing sanitary facilities for employees, trash receptacles and all safety devices as required during construction.

110 Calendar Days are listed in the contract for final completion. The contract days provided may be extended at the discretion of the owner in the event that materials cannot be supplied in a timely manner. If material delays are encountered, the Contractor shall de-mobilize at their expense during the rodeo event between May 20th, 2026 and May 25th, 2026 and secure the area as needed prior to the event. The intent is to have the facility completed and occupied prior to the event.

TAX EXEMPTION:

The Rodeo Arena Interlocal Cooperative is exempt from Federal, State, Municipal Sales and Use Taxes.

BID PROPOSAL

Proposal of _____
(Hereinafter called "Bidder"), organized and existing under the laws of the State of _____,
doing business as _____ * to **RODEO ARENA INTERLOCAL
COOPERATIVE**, (Hereinafter called "Owner"). In compliance with the Advertisement for Bids, Bidder hereby
proposes to perform all Work for the construction of WILL ROGERS STAMPEDE ARENA VIP MEZZANINE
in strict accordance with the Contract Documents within the time set forth therein and at the prices stated in
the attached Bid Schedule and the subsequent executed Work Order.

By submission of this bid, each Bidder certifies, and in the case of a joint bid each party certifies as to its own
organization, that this bid has been arrived at independently, without consultation, communication or
agreement as to any matter relating to this bid, with any other Bidder.

Bidder hereby agrees to commence work under this contract within ten (10) days of the date to be specified in
the **Notice to Proceed** and to complete the Project within **110** consecutive calendar days thereafter.

Bidder further agrees to pay as liquidated damages, and not as a penalty, the sum of \$ **250.00** for each
consecutive calendar day thereafter as provided in Section 15 of the General Conditions.

No Bidder may withdraw a bid within 30 days after the actual opening thereof. Each bid must be accompanied
by a Bid Bond payable to Owner for 5% of the amount bid, a Business Relationship Affidavit, and a Non-
Collusion Affidavit.

Bidder acknowledges receipt of the following **addenda**: _____
_____.

Bidder agrees to perform all the Work described in the Contract Documents for the unit prices listed in the Bid
Schedule and in accordance with terms of this Contract and the Work Order.

*Insert "a corporation", "a partnership" or "an individual", as applicable.

BIDDERS CONTACT INFORMATION

COMPANY NAME: _____

PRIMARY CONTACT - PRINT NAME: _____

SIGNATURE: _____

DATE: _____

ADDRESS: _____

CITY/STATE: _____

PHONE NO: _____

EMAIL: _____

STATE OF INCORPORATION: _____

BID SCHEDULE

Lump Sum Amount: _____
(written in numbers)

Lump Sum Amount: _____

(written in words)

Prices listed above are lump sum to include all material, equipment and labor required to provide a complete finished mezzanine project in accordance with the attached plans and specifications.

EXPERIENCE QUESTIONNAIRE

Submitted to: _____

- _____ A Corporation
- _____ A Co-Partnership
- _____ An Individual

By: _____

Principal Office: _____

1. How many years has your organization been in business as a general Contractor under your present business name? _____

2. How many years of experience in concrete and steel structure construction do you have?

- a) As a general Contractor: _____?
- b) As a sub-contractor: _____?

3. List below the projects your organization has completed, of similar size and scope, within the last five-years:

CONTRACT AMOUNT	TYPE OF PROJECT	WHEN COMPLETED	NAME & ADDRESS OF OWNER

4. List names, addresses and telephone numbers of persons to be contacted for information on projects listed in Question 3:

NAME OF OWNER	NAME, ADDRESS, PHONE NO. OF PERSON TO CONTACT

5. Have you ever failed to complete any work awarded to you? _____
 If so, where and why: _____

6. Has any officer or partner of your organization ever been an officer or partner of any other organization that failed to complete a construction contract? _____
 If so, state the name of the individual, other organization and reason therefore:

7. Has any officer or partner of your organization ever failed to complete a construction contract handled in his own name? _____
 If so, state the name of the individual, name of the owner and reason therefore:

8. In what other lines of business are you financially interested?

SUPERINTENDENT QUESTIONNAIRE

Contract documents require that a competent, resident superintendent be on the Work site at all times. Each BIDDER shall provide the following information, covering the past five years, concerning the superintendent proposed for actual field execution of the Work:

Superintendent's Name: _____

Address: _____

Previous Related Experience (Cover the last five years):

PROJECT NAME	LOCATION	POSITION/TITLE

BUSINESS RELATIONSHIPS AFFIDAVIT

STATE OF OKLAHOMA)
)
COUNTY OF _____) ss.

_____, of lawful age, being first duly sworn upon oath, states that (s)he is the agent authorized by the Bidder to submit the attached bid. Affiant further states that the nature of any partnership, joint venture or other business relationship presently in effect or which existed within one (1) year prior to the date of this statement with the architect, Engineer or other party to the Project is as follows:

Affiant further states that any such business relationship presently in effect or which existed within one (1) year prior to the date of this statement between any officer or director of the bidding company and any officer or director of the architectural or engineering firm or other party to the Project is as follows:

Affiant further states that the names of all persons having any such business relationships and the positions they hold with their respective companies or firms are as follows:

(if none of the business relationships hereinabove mentioned exist, Affiant should so state.)

Affiant

Subscribed and sworn to before me this _____ day of _____, 20_____.

Notary Public
My Commission Expires:

NOTE: This form must be submitted with the bid.

Non-Collusion Affidavit

STATE OF OKLAHOMA)
) ss
COUNTY OF _____)

_____, of lawful age, being first duly sworn, on oath says:

1. (S)He is the duly authorized agent of _____, the bidder submitting the competitive bid which is attached to this statement, for the purpose of certifying the facts pertaining to the existence of collusion among bidders and between bidders and state officials or employees, as well as facts pertaining to the giving or offering of things of value to government personnel in return for special consideration in the letting of any contract pursuant to the bid to which this statement is attached;
2. (S)He is fully aware of the facts and circumstances surrounding the making of the bid to which this statement is attached and has been personally and directly involved in the proceedings leading to the submission of such bid; and
3. Neither the bidder nor anyone subject to the bidder's direction or control has been a party:
 - a. to any collusion among bidders in restraint of freedom of competition by agreement to bid at a fixed price or to refrain from bidding,
 - b. to any collusion with any state official or employee as to quantity, quality or price in the prospective contract, or as to any other terms of such prospective contract, nor
 - c. in any discussions between bidders and any state official concerning exchange of money or other thing of value for special consideration in the letting of a contract.

Name & Title _____

Address _____

County of _____

State of _____

Subscribed and sworn to before me this _____ day of _____, 20__.

Notary Public: _____

My commission expires: _____

NOTE: This form must be submitted with the bid.

CLAIM OR INVOICE AFFIDAVIT

STATE OF OKLAHOMA)
) ss.
COUNTY OF _____)

The undersigned, of lawful age, being first duly sworn upon oath, states that this invoice or claim is true and correct. Affiant further states that the work as shown by this invoice or claim, have been completed in accordance with the plans, specifications, orders or requests furnished to the Affiant. Affiant further states that (s)he has not paid, given or donated or agree to pay, give or donate, either directly or indirectly, to any elected official, officer or employee of the State of Oklahoma or The Rodeo Arena Interlocal Cooperative any money or any other thing of value to obtain payment or the award of this contract.

Affiant

Subscribed and sworn to before me this _____ day of _____, 20____.

Notary Public

My Commission Expires:

BID BOND

KNOW ALL MEN BY THESE PRESENTS, that we, the undersigned, _____ and _____, as Principal, and _____ as Surety, are hereby held and firmly bound unto RODEO ARENA INTERLOCAL COOPERATIVE, of ROGERS COUNTY, OKLAHOMA, (hereinafter called "OWNER"), in the penal sum of _____ DOLLARS (\$ _____) for the payment of which sum, well and truly to be made, we hereby jointly and severally bind ourselves, our heirs, executors, administrators, successors and assigns.

THE CONDITION OF THE ABOVE OBLIGATION is such that, whereas the Principal has submitted to the OWNER a certain BID, attached hereto and made a part hereof, to enter into Contract for _____, Project No. _____.

THE CONDITION OF THIS OBLIGATION is such that, if the OWNER shall make any award to the BIDDER, according to the terms of the advertised bidding documents of BID, made by the BIDDER therefore, and the BIDDER shall duly make and enter into Contract with the OWNER in accordance with the terms of said BID award and shall, in case of failure to do so, pay to the OWNER damages to which the OWNER may suffer by reason of such failure not exceeding the penalty of this Bond, then this obligation shall be null and void; otherwise, it shall be and remain in full force and effect. It being expressly understood and agreed that the liability of the Surety for any and all claims hereunder shall, in no event, exceed the penal amount of this obligation as herein stated.

The Surety, for value received, hereby stipulates and agrees that the obligations of said Surety and its Bonds shall in no way be impaired or affected by any extension of time within which the OWNER may accept such BID. Said Surety does hereby waive notice of any such extension.

IN WITNESS WHEREOF, the Principal and Surety have hereunto set their hands and seals and such of them as are corporations have caused their corporate seals to be hereto affixed, and these presents to be signed by their proper officers, the day and year set forth below.

Signed, seal and dated this _____ day of _____, 20____.

Principal

By: _____
Printed Name and Title

Surety

By: _____
Printed Name and Title

ATTEST: (If by Corporation)

By: _____
Printed Name and Title

(Corporate Seal)

Address: _____

Subscribed and sworn to before me this _____ day of _____, 20_____.

(SEAL) _____
Notary Public

NOTICE OF CONTRACT AWARD

	CONTRACT #: SB-2025-4

Project Description: **WILL ROGERS STAMPEDE ARENA VIP MEZZANINE**

The Owner has considered the bid submitted by you for the above-described work in response to its Advertisement for Bids dated _____, 20____ and its Information for Bidders.

The Rodeo Arena Interlocal Cooperative accepted your Bid on _____, 20____ for the prices listed in the Bid Schedule.

If you fail to execute said agreement and to furnish required insurance certificates within fifteen (15) days from the date of this notice; the Owner will be entitled to consider all your rights arising out of the Owner's acceptance of your bid as abandoned and as a forfeiture of your bid bond. The Owner will be entitled to such other rights as may be granted by law.

You are required to return an acknowledged copy of this Notice of Award to the Owner.

Dated this _____ day of _____, 20_____.

Rodeo Arena Interlocal Cooperative

ACCEPTANCE OF NOTICE

Receipt of the above Notice of Award is hereby acknowledged by _____
this _____ day of _____, _____.

By: _____ Title: _____ Date: _____

CONTRACT

This contract, made and entered into by and between the Rodeo Arena Interlocal Cooperative (“Owner”) and:

_____ (“Contractor”)

for construction services for the WILL ROGERS STAMPEDE ARENA VIP MEZZANINE.

WHEREAS: the Contractor is the lowest responsible bidder for:

PROJECT: SB-2025-4 – WILL ROGERS STAMPEDE ARENA VIP MEZZANINE

for the prices listed in the Bid Schedule, as accepted by the Rodeo Arena Interlocal Cooperative at the _____ special meeting.

THEREFORE, the Contractor, for the consideration herein named, hereby agrees to do and complete the work above mentioned in accordance with the plans and specifications contained in the bidding documents as adopted and approved by the Owner and on file in the office of Chairman which plans and specifications are made a part of this contract by reference and in accordance with the following General Conditions, Sections 1-31.

It is further agreed that the Contractor will commence said work within 10 days from the date of the Notice to Proceed and perform the same vigorously and continuously and complete the said Project.

The Notice to Bidders, the Information for Bidders, the Special and General provisions of the plans and specifications and the Contractor's Bid Proposal including the Bid Schedule, each of said instruments on file in the office of the Chairman, are, by reference thereto, made a part of this contract as if fully set forth herein or attached hereto.

IN WITNESS WHEREOF, the Rodeo Arena Interlocal Cooperative (“Owner”) and

_____, Contractors hereunto set their hands and seals the day of _____, 20_____.

Louie Gardner, Chairman
Rodeo Arena Interlocal Cooperative

SEAL

ATTEST:

Name: _____

My commission expires

Contractor:

SEAL

Contractor

ATTEST:

(Signature of notary officer)

Contractor Signature

Typed Name & Title

My commission expires:

GENERAL CONDITIONS

1. Definitions
2. Additional Instructions & Detail Drawings
3. Scheduled, Reports and Records
4. Drawings and Specifications
5. Shop Drawings
6. Materials, Services & Facilities
7. Inspection & Testing
8. Substitutions
9. Patents
10. Surveys, Permits, Regulations
11. Protection of Work, Property
12. Supervision by Contractor
13. Changes in the Work
14. Changes in Contract Price
15. Time Completion & Liquidated Damages
16. Correction of Work
17. Subsurface Conditions
18. Suspension of Work, Termination & Delay
19. Payments to Contractor
20. Acceptance of Final Payment as Release
21. Insurance
22. Contract Security
23. Assignments
24. Indemnification
25. Separate Contracts
26. Subcontracting Persons
27. Engineer's Authority
28. Land and Rights-of-Way
29. Guaranty
30. Arbitration
31. Taxes

1. **DEFINITIONS:** Wherever used in the Contract Documents, the following terms shall have the meanings indicated and shall be applicable to both the singular and plural thereof:
 - a. **Addenda:** Written or graphic instruments issued prior to the execution of the Contract which modify or interpret the Contract Documents, Drawings and Specifications by additions, deletions, clarifications or corrections.
 - b. **Bid:** The offer or proposal of the Bidder submitted on the prescribed form setting forth the prices for the Work to be performed.
 - c. **Bidder:** Any person, firm or corporation submitting a bid for the Work.
 - d. **Bonds:** Bid, performance, payment (statutory) and maintenance bonds and other instruments of security furnished by the Contractor and the Contractor's surety in accordance with the Contract Documents.
 - e. **Change Order:** A written order to the Contractor authorizing an addition, deletion or revision in the Work within the general scope of the Contract Documents or authorizing an adjustment in the Contract Price or Contract Time.
 - f. **Contract:** This Contract, including the General Conditions and any written amendments hereto.
 - g. **Contract Documents:** This Contract, including Advertisement for Bids, Information for Bidders, Bid, Bid Bond, Payment (Statutory) Bond, Performance Bond, Notice of Award, Notice to Proceed, Change Order, Drawings, Specifications and Addenda.
 - h. **Contract Price:** The total monies payable to the Contractor under the terms and conditions of the Contract Documents.
 - i. **Contract Time:** The number of calendar days stated in the Contract Documents for the completion of the Work.
 - j. **Contractor:** The person, firm or corporation with whom the Owner has executed the Contract.
 - k. **Drawings:** The parts of the Contract Documents which show the characteristics and scope of the Work to be performed and which have been prepared or approved by the Engineer.

- l. Engineer: The person, firm or corporation named as such in the Contract Documents.
- m. Field Order: A written order effecting a change in the Work not involving an adjustment in the Contract Price or an extension of the Contract Time, issued by the Engineer to the Contractor during construction.
- n. Notice to Proceed: Written communication issued by the Owner to the Contractor authorizing him/her to proceed with the Work and establishing the date for commencement of the Work.
- o. Notice of Award: The written notice by Owner to the apparently successful Bidder stating that, upon compliance by the apparently successful Bidder with the conditions enumerated therein within the time specified, Owner will sign and deliver the Contract.
- p. Owner: The Rodeo Arena Interlocal Cooperative - Claremore, Oklahoma.
- q. Project: The undertaking to be performed as provided in the Contract Documents.
- r. Resident Project Representative: The authorized representative of the Owner who is assigned to the Project site or any part thereof.
- s. Shop Drawings: All drawings, diagrams, illustrations, brochures, schedules and other data which are prepared by the Contractor, a Subcontractor, manufacturer, Supplier or distributor which illustrate how specific portions of the Work shall be fabricated or installed.
- t. Specifications: A part of the Contract Documents consisting of written descriptions of a technical nature of materials, equipment, construction systems, standards and workmanship.
- u. Subcontractor: An individual, firm or corporation having a direct contract with Contractor or with any other Subcontractor for the performance of a part of the Work at the site.
- v. Substantial Completion: That date certified by the Engineer when the construction of the Project or a specified part thereof is sufficiently completed, in accordance with the Contract Documents, to allow the Project or specified part to be utilized for the purposes for which it is intended.
- w. Supplier: Any person or organization who supplies materials or equipment for the Work, including that fabricated to a special design, but who does not perform labor at the site.
- x. Work: All labor necessary to produce the construction required by the Contract Documents and all materials and equipment incorporated or to be incorporated in the Project.
- y. Work Order: A supplemental agreement made under the original contract specific to the scope of work agreed to by the Owner and Contractor.
- z. Written Notice: Any notice in writing to any party to the Contract regarding any part of this Contract. Said Written Notice shall be considered delivered and the service thereof completed when posted by certified or registered mail to said party at their last given address or delivered in person to said party or their authorized representative at the Project site.

2. ADDITIONAL INSTRUCTIONS AND DETAIL DRAWINGS:

- a. The Contractor may be furnished additional instructions and detail Drawings by the Engineer as necessary to carry out the Work required by the Contract Documents.
- b. The additional Drawings and instructions thus supplied will become a part of the Contract Documents. The Contractor shall carry out the Work in accordance with the additional detail Drawings and instructions.

3. SCHEDULES, REPORTS AND RECORDS:

- a. The Contractor shall submit to the Owner such schedule of quantities and costs, progress schedules, payrolls, reports, estimates, records, and other data, where applicable, as are required by the Contract Documents for the Work to be performed.
- b. Prior to the first partial payment estimate, the Contractor shall submit construction progress schedules showing the order in which the Contractor proposes to carry out the Work, including dates at which the various parts of the Work will be started, estimated date of completion of each part and, as applicable:
 - (1) The dates at which special detail Drawings will be required; and
 - (2) Respective dates for submission of Shop Drawings, the beginning of manufacture, the testing and the installation of materials, supplies and equipment.
- c. The Contractor shall also submit a schedule of payments the Contractor anticipates will be earned during the course of the Work.

4. DRAWINGS AND SPECIFICATIONS:

- a. The Drawings and Specifications are tools to be used by the Contractor to enable the Contractor to furnish all labor, materials, tools, equipment and transportation necessary for the proper performance of the Work in accordance with the Contract Documents and all incidental Work necessary to complete the Project in an acceptable manner, ready for use, occupancy or operation by the Owner.
- b. In case of conflict between the Drawings and the Specifications, the Specifications shall govern. Figure dimensions and drawings shall govern over scale dimensions and detail drawings shall govern over general drawings.
- c. Any discrepancies found between the Drawings and Specifications and site conditions or any inconsistencies or ambiguities in the Drawings or Specifications shall be immediately reported, in writing, to the Engineer, who shall promptly correct such inconsistencies or ambiguities in writing. Work done by the Contractor after discovery of such discrepancies, inconsistencies or ambiguities shall be done at the Contractor's risk.

5. SHOP DRAWINGS:

- a. The Contractor shall provide Shop Drawings as may be necessary for the performance of the Work as required by the Contract Documents. The Engineer shall promptly review all Shop Drawings. The Engineer's approval of any Shop Drawing shall not release the Contractor from responsibility for deviations from the Contract Documents. The approval of any Shop Drawing that substantially deviates from the requirement of the Contract Documents shall be evidenced by a Change Order.
- b. When submitted for the Engineer's review, Shop Drawings shall bear the Contractor's certification that he has reviewed, checked and approved the Shop Drawings and that they are in conformance with the requirements of the Contract Documents.

6. MATERIALS, SERVICES AND FACILITIES:

- a. It is understood that, except as otherwise specifically stated in the Contract Documents, the Contractor shall provide and pay for all materials, labor, tools, equipment, water, light, power, transportation, supervision, temporary construction of any nature and all other services and facilities of any nature whatsoever necessary to execute, complete and deliver the Work within the specified time.

- b. Materials and equipment shall be so stored as to preserve their quality and fitness for the Work. Stored materials and equipment to be incorporated in the Work shall be located to facilitate prompt inspection.
- c. Manufactured articles, materials and equipment shall be applied, installed, connected, erected, used, cleaned and conditioned as directed by the manufacturer.
- d. Materials, supplies and equipment shall be in accordance with samples submitted by the Contractor and approved by the Engineer.
- e. Materials, supplies or equipment to be incorporated into the Work shall be purchased by the Contractor or the Subcontractor free and clear of chattel mortgages, conditional sales contracts or other agreements by which an interest is retained by the seller.

7. INSPECTION AND TESTING:

- a. All materials and equipment used in the construction of the Project shall be subject to adequate inspection and testing in accordance with generally accepted standards as required and defined in the Contract Documents.
- b. The Owner shall provide all inspection and testing services not required by the Contract Documents.
- c. The Contractor shall provide, at the Contractor's expense, the testing and inspection services required by the Contract Documents.
- d. If the Contract Documents, laws, ordinance, rules, regulations or orders of any public authority having jurisdiction require any specific work to be inspected, tested or approved by someone other than the Contractor, the Contractor will give the Engineer timely notice of readiness. The Contractor will then furnish the Engineer the required certificates of inspection, testing or approval.
- e. Inspections, tests or approvals by the Engineer or others shall not relieve the Contractor from the obligation to perform the Work in accordance with the requirements of the Contract Documents.
- f. The Engineer and the Engineer's representatives will at all times have access to the Work. In addition, authorized representatives and agents of any participating Federal or State agency shall be permitted to inspect all work, materials, payrolls, records of personnel, invoices of materials and other relevant data and records. The Contractor will provide proper facilities for such access and observation of the Work and for any inspection or testing thereof.
- g. If any Work is covered contrary to the written instructions of the Engineer, it must, if requested by the Engineer, be uncovered for the Engineer's observation and the covering replaced at the Contractor's expense.
- h. If the Engineer considers it necessary or advisable that covered Work be inspected or tested by others, the Contractor, at the Engineer's request, will uncover, expose or otherwise make available for observation, inspection or testing, as the Engineer may require, that portion of the Work in question, furnishing all necessary labor, materials, tools and equipment. If it is found that such Work is defective, the Contractor will bear all expenses of such uncovering, exposing, observing, inspecting and testing and of satisfactory reconstruction. If, however, such Work is not found to be defective, the Contractor will be allowed an increase in the Contract Price or an extension of the Contract Time, or both, directly attributable to such uncovering, exposing, observing, inspecting, testing and reconstruction and an appropriate Change Order shall be issued.

8. SUBSTITUTIONS: Whenever a material, article or piece of equipment is identified on the Drawings or Specifications by referenced to brand name or catalog number, it shall be understood that this is

referenced for the purpose of defining the performance or other salient requirements and that other products of equal capacities, quality and function may be considered. The Contractor may recommend the substitution of a material, article or piece of equipment of equal substance and function for those referred to in the Contract Documents by reference to brand name or catalog number and if, in the opinion of the Engineer, such material, article or piece of equipment is of equal substance and function to that specified, the Engineer may approve its substitution and use by the Contractor. Any cost differential shall be deductible from the Contract Price and the Contract Documents shall be appropriately modified by Change Order. The Contractor warrants that if substitutes are approved, no major changes in the function or general design of the Project will result. Incidental changes or extra component parts required to accommodate the substitute will be made by the Contractor without a change in the Contract Price or Contract Time.

9. PATENTS: The Contractor shall pay all applicable royalties and license fees and shall defend all suits or claims for infringement of any patent rights and save the Owner harmless from loss on account thereof, except that the Owner shall be responsible for any such loss when a particular process, design or product of a particular manufacturer or manufacturers is specified; however, if the Contractor has reason to believe that the design, process or product specified is an infringement of a patent, the Contractor shall be responsible for such loss unless the Contractor promptly gives such information to the Engineer.
10. SURVEYS, PERMITS, REGULATIONS:
 - a. If called for in the Drawings, the Owner shall furnish all boundary surveys and establish all base lines for locating the principal component parts of the Work, together with a suitable number of benchmarks adjacent to the Work as shown in the Contract Documents. The Owner shall develop and make all detail surveys needed for construction, such as slope stakes, stakes for pipe locations and other working points, lines, elevations and cut sheets.
 - b. The Contractor shall carefully preserve benchmarks, reference points and stakes and, in case of willful or careless destruction, shall be charged with the resulting expense and shall be responsible for any mistake that may be caused by their unnecessary loss or disturbance.
 - c. Permits and licenses of a temporary nature necessary for the performance of the Work shall be secured and paid for by the Contractor unless otherwise stated in the Supplemental General Conditions. Permits, licenses and easements for permanent structures or permanent changes in existing facilities shall be secured and paid for by the Owner unless otherwise specified. The Contractor shall give all notices and comply with all laws, ordinances, rules and regulations bearing on the conduct of the Work as drawn and specified. If the Contractor observes that the Contract Documents are at variance therewith, the Contractor shall promptly notify the Engineer in writing and any necessary changes shall be adjusted as provided in Section 13, CHANGES IN THE WORK.
11. PROTECTION OF WORK, PROPERTY AND PERSONS:
 - a. The Contractor will be responsible for initiating, maintaining and supervising all safety precautions and program in connection with the Work. The Contractor will take all necessary precautions for the safety of and will provide the necessary protection to prevent damage, injury or loss to all employees on the Work and other persons who may be affected thereby and for the protection of all the Work and all materials or equipment to be incorporated therein, whether in storage on or off the site, and other property at the site or adjacent thereto, including trees, shrubs, lawns, walks, pavements, roadways, structures and utilities not designated for removal, relocation or replacement in the course of construction.
 - b. The Contractor will comply with all applicable laws, ordinances, rules, regulations and orders of any public body having jurisdiction. The Contractor will erect and maintain, as required by the conditions and progress of the Work, all necessary safeguards for safety and protection. The Contractor will notify owners of adjacent utilities when performance of the Work may affect them. The Contractor will remedy all damage, injury or loss to any property caused, directly or indirectly, in whole or in part, by the Contractor or any Subcontractor or anyone

directly or indirectly employed by any of them or anyone for whose acts any of them may be liable, except damage or loss attributable to the fault of the Contract Documents or to the acts or omissions of the Owner or the Engineer or anyone employed by either them or anyone for whose acts either of them may be liable, and not attributable, directly or indirectly, in whole or in part, to the fault or negligence of the Contractor.

- c. In emergencies affecting the safety of persons or the Work or property at the site or adjacent thereto, the Contractor, without special instructions or authorization from the Engineer or Owner, shall act to prevent the threatened damage, injury or loss. The Contractor will give the Engineer prompt written notice of any significant changes in the Work or deviations from the Contract Documents caused thereby and a Change Order shall thereupon be issued covering the changes and deviations involved.
12. **SUPERVISION BY CONTRACTOR:** The Contractor will supervise and direct the Work. He will be solely responsible for the means, methods, techniques, sequences and procedures of construction. The Contractor will employ and maintain on the Work a qualified supervisor or superintendent who shall have been designated in writing by the Contractor as the Contractor's representative at the site. The supervisor shall have full authority to act on behalf of the Contractor and all communications given to the supervisor shall be as binding as if given to the Contractor. The supervisor shall be present on the site at all times as required to perform adequate supervision and coordination of the Work.
13. **CHANGES IN THE WORK:**
- a. The Owner may, at any time, as the need arises, order changes within the scope of the Work without invalidating the Contract. If such changes increase or decrease the amount due under the Contract Documents or in the time required for performance of the work, an equitable adjustment shall be authorized by Change Order.
 - b. The Engineer may also, at any time, by issuing a field order, make changes in the details of the Work. The Contractor shall proceed with the performance of any changes in the Work so ordered by the Engineer unless the Contractor believes that such field order entitles the Contractor to a change in Contract Price or Time, or both, in which event, the Contractor shall give the Engineer written notice thereof within seven (7) days after the receipt of the ordered change. Thereafter, the Contractor shall document the basis for the change in Contract Price or Time within thirty (30) days. The Contractor shall not execute such changes pending the receipt of an executed Change Order or further instruction from the Owner.
14. **CHANGES IN CONTRACT PRICE:** The Contract Price may be changed only by a Change Order. The value of any Work covered by a Change Order or of any claim for increase or decrease in the Contract Price shall be determined by one or more of the following methods in the order of precedence listed below:
- a. Unit prices previously approved;
 - b. An agreed lump sum.
15. **TIME FOR COMPLETION AND LIQUIDATED DAMAGES:**
- a. The date of beginning and the time for completion of the Work are essential conditions of the Contract Documents and the Work embraced shall be commenced on a date specified in the Work Order.
 - b. The Contractor will proceed with the Work at such rate of progress as to ensure full completion within the Contract Time. It is expressly understood and agreed by and between the Contractor and the Owner that the Contract Time for the completion of the Work described herein is a reasonable time, taking into consideration the average climatic and economic conditions and other factors prevailing in the locality of the Work.

- c. If the Contractor shall fail to complete the Work within the Contract Time or extension of time granted by the Owner, then the Contractor will pay to the Owner the amount for liquidated damages as specified in the Bid for each calendar day the Contractor shall be in default after the time stipulated in the Contract Documents. The parties agree that it would be extremely difficult or impracticable to fix the amount of Owner's damages sustained by reason of Contractor default in reaching substantial completion of the Work within the Contract Time and that the amount of liquidated damages specified represents the parties' reasonable estimation of actual damages.
- d. The Contractor shall not be charged with liquidated damages or any excess cost when the delay in completion of the Work is due to the following and the Contractor has promptly given written notice of such delay to the Owner or Engineer:
 - (1) Any preference, priority or allocation order duly issued by the Owner;
 - (2) Unforeseeable causes beyond the control and without the fault or negligence of the Contractor, including but not restricted to acts of God, acts of the public enemy, acts or the Owner, acts of another contractor in the performance of a contract with the

Owner, fires, flood, epidemics, quarantine, restrictions, strikes, freight embargoes and abnormal and unforeseeable weather; and
 - (3) Any delays of Subcontractors occasioned by any of the causes specified in paragraphs 15d(1) and 15d(2) of this article.

16. CORRECTION WORK:

- a. The Contractor shall promptly remove from the premises all Work rejected by the Engineer for failure to comply with the Contract Documents, whether incorporated in the construction or not, and the Contractor shall promptly replace and re-execute the Work in accordance with the Contract Documents without expense to the Owner and shall bear the expense of making good all the Work of other contractors destroyed or damages by such removal or replacement.
- b. All removal and replacement work shall be done at the Contractor's expense. If the Contractor does not take action to remove such rejected Work within ten (10) days after receipt of written notice, the Owner may remove such Work and store the materials at the expense of the Contractor.

17. SUBSURFACE CONDITIONS:

- a. The Contractor shall promptly, before such conditions are disturbed except in the event of an emergency, notify the Owner by Written Notice of:
 - (1) Subsurface or latent physical conditions at the site differing materially from those indicated in the Contract Documents; or
 - (2) Unknown physical conditions at the site of an unusual nature which differ materially from those ordinarily encountered and generally recognized as inherent in the Work the character provided for in the Contract Documents.
- b. The Owner shall promptly investigate the conditions and, if it is found that such conditions do so materially differ and cause an increase or decrease, an adjustment shall be made and the Contract Documents shall be modified by a Change Order. Any claim of the Contractor for adjustment hereunder shall not be allowed unless the required Written Notice has been given and provided that the Owner may, if the Owner determines the facts so justify, consider and adjust any claims asserted before the date of final payment.

18. SUSPENSION OF WORK, TERMINATION AND DELAY:

- a. The Owner may suspend the Work or any portion thereof for a period of not more than ninety (90) days or until such further time as agreed upon by the Contractor in a Written Notice to the Contractor and the Engineer fixing the date on which Work shall be resumed. The Contractor will resume that Work on the date so fixed. The Contractor will be allowed an increase in the Contract Price or an extension of the Contract Time, or both, for any costs and/or delays incurred which are directly attributable to any suspension.
- b. If any of the following conditions occur:
 - (1) The Contractor is adjudged bankrupt or insolvent or makes a general assignment for the benefit of its creditors;
 - (2) A trustee or receiver is appointed for the Contractor or for any of its property;
 - (3) Contractor files a petition to take advantage of any debtor's act or to reorganize under bankruptcy of applicable laws;
 - (4) The Contractor repeatedly fails to supply sufficiently skilled workmen or suitable materials or equipment;
 - (5) The Contractor repeatedly fails to make prompt payments to Subcontractors or for labor, materials or equipment;
 - (6) The Contractor disregards laws, ordinance, rules, regulations or orders of any public body having jurisdiction over the Work;
 - (7) The Contractor disregards the authority of the Engineer or otherwise violates any provision of the Contract Documents; then the Owner may, without prejudice to any other right or remedy and after giving the Contractor and its surety a minimum of ten (10) days from delivery of a Written Notice, terminate the services of the Contractor and take possession of the Project and of all materials, equipment, tools, construction equipment and machinery thereon owned by the Contractor and finish the Work by whatever method the Owner may deem expedient. In such case, the Contractor shall not be entitled to receive any further payment until the Work is finished. If the unpaid balance of the Contract Price exceeds the direct and indirect costs of completing the Project, including compensation for additional professional services, such excess shall be paid to the Contractor. If such costs exceed such unpaid balance, the Contractor will pay the difference to the Owner. Such costs incurred by the Owner will be determined by the Engineer and incorporated in a Change Order.
- c. Where the Contractor's services have been so terminated by the Owner, said termination shall not affect any right of the Owner against the Contractor then existing or which may thereafter occur. Any retention or payment of monies by the Owner due the Contractor will not release the Contractor from compliance with the Contract Documents.
- d. After ten (10) days from the delivery of a Written Notice to the Contractor and the Engineer, the Owner may, without cause and without prejudice to any other right or remedy, elect to abandon the Project and terminate the Contract. In such case, the Contractor shall be paid for all Work executed and any expense sustained plus a reasonable profit.
- e. If, through no act or fault of the Contractor, the Work is suspended for a period of more than ninety (90) days by the Owner or under an order of court or other public authority or the Engineer fails to act on any request for payment within thirty (30) days after it is submitted or the Owner fails to pay the Contractor substantially the sum approved by the Engineer or awarded by arbitrators within thirty (30) days of its approval and presentation, then the Contractor may, after ten (10) days from delivery of a Written Notice to the Owner and the

Engineer, terminate the Contract and recover from the Owner payment for all Work executed and all expenses sustained.

In addition to and in lieu of terminating the Contract, if the Engineer has failed to act on a request for payment or if the Owner has failed to make payment as aforesaid, the Contractor may, upon ten (10) days Written Notice to the Owner and Engineer, stop the Work until paid all amounts then due, in which event and upon resumption of the Work, Change Orders shall be issued to adjust the Contract Price or extend the Contract Time, or both, to compensate for the costs and delays attributable to the stoppage of the Work.

- f. If the performance of all or any portion of the Work is suspended, delayed or interrupted is a result of a failure by the Owner or Engineer to act within the time specified in the Contract Documents or if no time is specified, within a reasonable time, an adjustment in the Contract Price or an extension of the Contract Time, or both, shall be made by Change Order to compensate the Contractor for the costs and delays unnecessarily caused by the failure of the Owner or Engineer.

19. PAYMENT TO CONTRACTOR:

- a. At least ten (10) days before each progress payment falls due (but not more often than once a month), the Contractor will submit to the Engineer a partial payment estimate filled out and signed by the Contractor, covering the Work performed during the period covered by the partial payment estimate and supported by such data as the Engineer may reasonably require. If payment is requested on the basis of materials and equipment not incorporated in the Work but delivered and suitably stored at or near the site, the partial payment estimate shall also be accompanied by supporting data, satisfactory to the Owner, which will establish the Owner's title to the material and equipment and protect the Owner's interest therein, including applicable insurance. The Engineer will, within ten (10) days after the receipt of each partial payment estimate, either indicate approval of payment in writing and present the partial payment estimate to the Owner or return the partial payment estimate to the Contractor indicating in writing the reasons for refusing to approve payment. In the latter case, the Contractor may make the necessary corrections and resubmit the partial payment estimate. The Owner will, within ten (10) days of presentation of an approved partial payment estimate, pay the Contractor a progress payment on the basis of the approved partial payment estimate less the retainage. The retainage shall be an amount equal to 5% of said estimate. Upon Substantial Completion of the Work, any amount retained may be paid to the Contractor. When the Work has been Substantially Completed except for work which cannot be completed because of weather conditions, lack of materials or other reasons which, in the judgment of the Owner, are valid reasons for non-completion, the Owner may make additional payments, retaining at all times an amount sufficient to cover 150% of the estimated cost of the Work still to be completed.
- b. The request for payment may also include an allowance for the cost of major materials and equipment suitably stored either at or near the site.
- c. Prior to Substantial Completion, the Owner, with the approval of the Engineer and with the concurrence of the Contractor, may use any completed or substantially completed portions of the Work. Such use shall not constitute an acceptance of such portions of the Work.
- d. The Owner shall have the right to enter the premises for the purpose of doing work not covered by the Contract Documents. This provision shall not be construed as relieving the Contractor of the sole responsibility for the care and protection of the Work or the restoration of any damaged Work except such as may be caused by agents or employees of the Owner.
- e. Upon completion and acceptance of the Work, the Engineer shall issue a certificate attached to the final payment request that the Work has been accepted under the conditions of the Contract Documents. The entire balance found to be due to the Contractor, including the retained percentages, except such sums as may be lawfully retained by the Owner, shall be paid to the Contractor within thirty (30) days of completion and acceptance of the Work.

- f. The Contractor will indemnify and save the Owner or the Owner's agents harmless from all claims growing out of the lawful demand of Subcontractors, laborers, workmen, mechanics, material men and furnishers of machinery and parts therefor, equipment, tools and supplies incurred in the furtherance of the performance of the Work. The Contractor shall, at the Owner's request, furnish satisfactory evidence that all obligations of the nature designated above have been paid, discharged or waived. If the Contractor fails to do so, the Owner may, after having notified the Contractor, either pay unpaid bills or withhold from the Contractor's unpaid compensation a sum of money deemed reasonably sufficient to pay any and all such lawful claims until satisfactory evidence is furnished that all liabilities have been fully discharged, whereupon payment to the Contractor shall be resumed in accordance with the terms of the Contract Documents. In no event shall these provisions be construed to impose any obligations upon the Owner to either the Contractor, the Contractor's surety or any third party. In paying any unpaid bills of the Contractor, any payment so made by the Owner shall be considered as a payment made under the Contract Documents by the Owner to the Contractor and the Owner shall not be liable to the Contractor for any such payments made in good faith.
- g. If the Owner failed to make payment within thirty (30) days after approval by the Engineer, in addition to other remedies available to the Contractor, there shall be added to each such payment interest at the maximum legal rate commencing on the first day after said payment is due and continuing until the payment is received by the Contractor.
20. **ACCEPTANCE OF FINAL PAYMENT AS RELEASE:** Acceptance by the Contractor of final payment shall be and shall operate as a release to the Owner of all claims and all liability to the Contractor other than claims in stated amounts as may be specifically excepted by the Contractor for all things done or furnished in connection with this Work and for every act and neglect of the Owner and others, relating or arising out of this Work. Any payment, however, final or otherwise, shall not release the Contractor or its sureties from any obligations under the Contract Documents or the performance of the payment bonds.
21. **INSURANCE:**
- a. The Contractor shall purchase and maintain such insurance as will protect it from claims set forth below which may arise out of or result from the Contractor's execution of the Work, whether such execution be by the Contractor, any Subcontractor or by anyone directly or indirectly employed by any of them or by anyone for whose acts any of them may be liable.
- (1) Claims under Workers' Compensation, disability benefit and other similar employee benefit acts;
 - (2) Claims for damages because of bodily injury, occupational sickness or disease or death of employees;
 - (3) Claims for damages because of bodily injury, sickness or disease or death of any person other than employees;
 - (4) Claims for damages covered by the usual personal injury liability coverage which are sustained by:
 - (a) Any person as a result of an offense directly or indirectly related to the employment of such person by the Contractor; or
 - (b) Any other person;
 - (5) Claims for damages because of injury to or destruction of tangible property, including loss of use resulting there from.
- b. Certificates of insurance acceptable to Owner shall be filed with the Owner prior to commencement of Work. These certificates shall contain a provision that coverages afforded

under the policies will not be cancelled unless at least fifteen (15) days' prior written notice has been given to the Owner.

- c. The Contractor shall procure and maintain, at the Contractor's own expense, during the Contract Time, liability insurance as hereinafter specified:
 - (1) Contractor's general public liability and property damage insurance, including vehicle coverage, issued to the Contractor and protecting the Contractor from all claims for personal injury, including death, and all claims for destruction of or damage to property arising out of or in connection with any operations under the Contract Documents, whether such operations be by the Contractor or by any Subcontractor employed by the Contractor. Insurance shall be written with a limit of liability of not less than \$175,000 for all damages arising out of bodily injury, including death, at any time resulting there from, sustained by any one person in any one accident, and a limit of liability of not less than \$1,000,000 aggregate for any such damages sustained by two or more persons in anyone accident. Insurance shall be written with a limit of liability of not less than \$25,000 for all property damage sustained by anyone person in anyone accident and a limit of liability not less than \$200,000 aggregate for any such damage sustained by two or more persons in any one accident.
 - (2) The Contractor shall acquire and maintain, if applicable, fire and extended coverage insurance upon the Project to the full insurable value thereof for the benefit of the Owner, the Contractor and the Subcontractors, as their interest may appear. This provision shall in no way release the Contractor or the Contractor's surety from obligations under the Contract Documents to fully complete the Project.
- d. The Contractor shall procure and maintain, at the Contractor's own expense, during the Contract Time, in accordance with the provisions of the laws of the State in which the work is performed, Workers' Compensation insurance, including occupational disease provisions, for all of the Contractor's employees at the site of the Project and, in case any Work is sublet, the Contractor shall require such Subcontractor similarly to provide Workers' Compensation insurance, including occupational disease provisions, for all of the latter's employees unless such employees are covered by the protection afforded by the Contractor. In case any class of employees engaged in hazardous work under this contract at the site of the Project is not protected under the Workers' Compensation Statute, the Contractor shall provide and shall cause each Subcontractor to provide adequate and suitable insurance for the protection of its employees not otherwise protected.
- e. The Contractor shall secure, if applicable, "all risk" type Builder's risk insurance for Work to be performed. Unless specifically authorized by the Owner, the amount of such insurance shall not be less than the Contract Price totaled in the Bid. The policy shall cover not less than the losses due to fire, explosion, hail, lightning, vandalism, malicious mischief, wind, collapse, riot, aircraft and smoke during the Contract Time and until the Work is accepted by the Owner. The policy shall name as the insured the Contractor and the Owner.

22. CONTRACT SECURITY:

- a. The Contractor shall, prior to commencement of work under a Work Order, furnish the Owner with a performance bond, a maintenance bond and a payment (statutory) bond in penal sums equal to the estimated total amount of the Work Order, conditioned upon the performance by the Contractor of all undertakings, covenants, terms, conditions and agreements of the Contract Documents and upon the prompt payment by the Contractor to all persons supplying labor and materials in the performance of the Work required by the Contract Documents. Such Bonds shall be executed by the Contractor and a corporate bonding company licensed to transact such business in the State of Oklahoma. The expense of these bonds shall be borne by the Contractor. If, at any time, a surety on any such Bond is declared bankrupt or loses its right to do business in the State of Oklahoma, Contractor shall, within ten (10) days after notice from the Owner, substitute another bond and surety, both of

which must be acceptable to Owner. The premiums on such bond shall be paid by the Contractor. No further payment shall be deemed due nor made until the new surety or sureties shall have furnished an acceptable bond to the Owner. Bonds are only required on Work Orders exceeding \$100,000.

23. ASSIGNMENTS: Neither the Contractor nor the Owner shall sell, transfer, assign or otherwise dispose of the Contract or any portion thereof or of any right, title or interest therein or any obligations thereunder without written consent of the other party.

24. INDEMNIFICATION:

a. The Contractor will indemnify and hold harmless the Owner and the Engineer and their agents and employees from and against all claims, damages, losses and expenses, including attorney's fees, arising out of or resulting from the performance of the Work, provided that any such claims, damages, loss or expense is attributable to bodily injury, sickness, disease or death or to injury to or destruction of tangible property, including the loss of use resulting therefrom, which is caused in whole or in part by any negligent or willful act or omission of the Contractor, any Subcontractor, anyone directly or indirectly employed by any of them or anyone for whose acts any of them may be liable.

b. In any and all claims against the Owner or the Engineer or any of their agents or employees by any employee of the Contractor, any Subcontractor, anyone directly or indirectly employed by an of them or anyone for whose acts any of them may be liable, the indemnification obligation shall not be limited in any way by any limitation on the amount or type of damages, compensation or benefits payable by or for the Contractor or any Subcontractor under the Workers' Compensation Act, disability benefits acts or other employee benefits acts.

c. The obligation of the Contractor under this paragraph shall not extend to the liability of the Engineer, its agents or employees arising out of the preparation or approval of maps, drawings, opinions, reports, surveys, change orders, designs or specifications.

25. SEPARATE CONTRACTS:

a. The Owner may perform additional work related to the Project or the Owner may let other contracts containing provisions similar to these. The Contractor will afford the other contractors who are parties to such contracts (or the Owner, if the Owner is performing the additional work) reasonable opportunity for the introduction and storage of materials and equipment and the execution of work and shall properly connect and coordinate the Work with theirs. If the proper execution or results of any part of the Contractor's Work depends upon the work of any other contractor, the Contractor shall inspect and promptly report to the Engineer any defects in such work that render it unsuitable for such proper execution and results.

b. If the performance of additional work by other contractors or the Owner is not noted in the Contract Documents prior to the execution of the Contract, Written Notice thereof shall be given to the Contractor prior to starting any such additional work. If the Contractor believes the performance of such additional work by the Owner or other involves it in additional expense or entitles it to an extension of the Contract Time, the Contractor may make a claim therefor as provided in Sections 13 and 14.

26. SUBCONTRACTING:

a. The Contractor may utilize the services of specialty subcontracts on those parts of the Work, which, under normal contracting practices, are performed by specialty Subcontractors.

b. The Contractor shall not award work to Subcontractor(s) in excess of fifty (50) percent of the Contract Price or in excess of fifty (50) percent of the labor and equipment required to install the Project without prior written approval of the Owner.

- c. The Contractor shall be as fully responsible to the Owner for the acts and omissions of its Subcontractors and of persons either directly or indirectly employed by them as the Contractor is for the acts and omissions of persons directly employed by the Contractor.
- d. The Contractor shall cause appropriate provisions to be inserted in all subcontracts relative to the work to bind Subcontractors to the Contractor by the terms of the Contract Documents insofar as applicable to the Work of Subcontractors' and to give the Contractor the same power regarding termination of any subcontract that the Owner may exercise over the Contractor under any provision of the Contract Documents.
- e. Nothing contained in this Contract shall create any contractual relationship between any Subcontractor and the Owner.

27. ENGINEER'S AUTHORITY:

- a. The Engineer shall act as the Owner's representative during the construction period, shall decide questions which may arise as to quality and acceptability of materials furnished and work performed and shall interpret the intent of the Contract Documents in a fair and unbiased manner. The Engineer will make visits to the site and determine if the Work is proceeding in accordance with the Contract Documents.
- b. The Contractor will be held strictly to the intent of the Contract Documents in regard to the quality of materials, workmanship and execution of the Work. Inspections may be made at the factory or fabrication plant of the source of material supply.
- c. The Engineer will not be responsible for the construction means, controls, techniques, sequences, procedures or construction safety.
- d. The Engineer shall promptly make decisions relative to interpretation of the Contract Documents.

28. LAND AND RIGHTS-OF-WAY:

- a. Prior to issuance of the Work Order, the Owner shall obtain all land and right-of-way necessary for the carrying out and completion of the Work to be performed pursuant to the Contract Documents, unless otherwise mutually agreed.
- b. The Owner shall provide the Contractor with information that delineates and describes the lands owned and right-of-way acquired.
- c. The Contractor shall provide, at its own expense and without liability to the Owner, any additional land and access thereto that the Contractor may desire for temporary construction facilities or for storage of materials.

29. GUARANTEE: The Contractor shall guarantee all materials and equipment furnished and Work performed for a: period of one (1) year from the date of Substantial Completion. The Contractor warrants, and guarantees for a period of one (1) year from the date of Substantial Completion of the system that the completed system is free from all defects due to faulty materials or, workmanship and the Contractor shall promptly make such corrections as may be necessary by reason of such defects, including the repairs of any damage to other parts of the system resulting from such defects. The Owner will give notice of observed defects with reasonable promptness. In the event the Contractor should fail to make such corrections, the Owner may do so and charge the Contractor the costs thereby incurred. The maintenance bond shall remain in full force and effect throughout the guarantee period.

30. ARBITRATION BY MUTUAL AGREEMENT:

- a. All claims, disputes and other matters in question arising out of or relating to the Contract Documents or the breach thereof, except for claims which have been waived by making an

acceptance of final payment as provided in Section 20, may be decided by arbitration if the parties mutually agree. Any agreement to arbitrate shall be in writing and shall be specifically enforceable under the prevailing arbitration law. The award rendered by the arbitrators shall be final and judgment may be rendered upon it in any court having jurisdiction thereof.

- b. Notice of the request for arbitration shall be filed in writing with the other party to the Contract Documents and a copy shall be filed with the Engineer. Request for arbitration shall in no event be made on any claim, dispute or other matter in question that would be barred by the applicable statute of limitations.
 - c. The Contractor will carry on the work and maintain the progress schedule during any arbitration proceedings unless otherwise mutually agreed in writing.
31. TAXES: The Owner shall provide the Contractor documentation to provide suppliers of material for the Project to remove sales tax from the cost of materials.

SUPPLEMENTAL GENERAL CONDITIONS

The provisions of the Supplemental General Conditions as described herein change, amend or supplement the General Conditions and shall supersede any conflicting provisions of this contract. All provisions of the General Conditions which are not changed, amended or supplemented remain in force.

1. Contract Approval
2. Contract Change Orders
3. Partial Payment Estimates
4. Conflict of Interest
5. Protection of Lives and Property
6. Remedies Requirements
7. Gratuities
8. Non-Resident Requirements
9. Payment for Material Stored on Site
10. Change Order Approval
11. Final Inspection
12. Partial Occupancy and Use
13. Permit Requirements
14. Cleanup Release
15. Drug and Alcohol Testing

1. CONTRACT APPROVAL:

- a. The Owner and the Contractor will furnish the Owner's attorney such evidence as is required to enable the Owner's attorney to complete and execute "Certificate of Owner's Attorney" (Section 14).

2. PARTIAL PAYMENT ESTIMATES:

- a. "Partial Payment Estimates" shall be used when making application for periodic payments due the Contractor.
- b. The Owner may, after consultation with the architect/Engineer, withhold or, on account of subsequently discovered evidence, nullify, in whole or in part, any approved partial payment estimate to such extent as may be necessary to protect the Owner from loss on account of:
 - (1) Defective work not remedied;
 - (2) Claims filed;
 - (3) Failure of Contractor to make payments properly to Subcontractors or suppliers;
 - (4) A reasonable doubt that the Work can be completed for the balance then unpaid;
 - (5) Damage to another contractor;
 - (6) Performance of Work in violation of the terms of the Contract Documents.
- c. Where Work on unit price items is substantially complete but lacks testing, clean-up and/or corrections, amounts shall be deducted from unit prices in partial payment estimates to amply cover such testing, cleanup and/or corrections.
- d. When the items in 2.b. and 2.c. are cured, payment shall be made for amounts withheld because of them.
- e. Payments will not be made that would deplete the retainage or place in escrow any funds required for retainage or invest the retainage for the benefit of the Contract.

3. CONFLICT OF INTEREST:

- a. Unacceptable Bidders:
 - (1) No Engineer or architect (individual or firm, including persons they employ) who has prepared plans and specifications will be considered an acceptable bidder. Any firm or corporation in which such Engineer or architect (including persons they employ) is an officer or an employee or holds or controls a substantial interest will not be considered an acceptable bidder.
 - (2) Contracts or purchases by the Contractor shall not be awarded or made to a supplier or manufacturer if the Engineer or architect (firm or individual) who prepared the plans and specifications has a corporate or financial affiliation with the supplier or manufacturer. Bids will not be awarded to firms or corporations owned or controlled wholly or in part by a member of the governing body of the Owner or to an individual who is such a member.
- b. None of the Owner's officers, employees or agents shall engage in the award or administration of this Contract if a conflict of interest, real or apparent would be involved. Such a conflict would arise when the employee, officer or agent, any member of his immediate family, his partner or an organization which employs him or is about to employ him, or any of the above, has a financial or other interest in the Contractor. None of the Owner's officers, employees or agents shall solicit or accept gratuities, favors or anything of monetary value from the Contractor or Subcontractor.

4. PROTECTION OF LIVES AND PROPERTY:

- a. In order to protect the lives and health of its employees performing the Work under the Contract, the Contractor shall comply with all 4 pertinent provisions of the Occupational Safety and Health, Administration (OSHA) and any State safety and health agency requirements.
- b. The Contractor alone shall be responsible for the safety, efficiency and adequacy of its plant, appurtenances and methods and for any damage, which may result from their failure or their improper construction, maintenance or operation.

5. REMEDIES: Unless otherwise provided in this Contract, all claims, counterclaims, disputes and other matters in question between the Owner and the Contractor arising out of or relating to this contract or the breach thereof will be decided by arbitration, if the parties mutually agree, or in a court of competent jurisdiction with the State in which the Owner is located.

- a. The arbitration provisions of this section may be initiated by either party to this contract by filing with the other party and the Engineer/architect a written request for arbitration.
- b. Upon agreement to arbitrate, each party to this contract will appoint one arbitrator and the two arbitrators will select the third arbitrator.
- c. The arbitrators will select a hearing location as close to the Project site as possible.
- d. The procedure for conducting the hearing will follow the Construction Industry Arbitration Rules of the American Arbitration Association.

6. GRATUITIES:

- a. If the Contractor or any of the Contractor's agents or representatives offers or gives gratuities (in the form of entertainment, gifts or anything of value) to any official, employee or agent of the Owner in an attempt to secure this Contract or favorable treatment in awarding, amending or making any determinations related to the performance of this Contract, the Owner may, by written notice to the Contractor, terminate this Contract. The Owner may also pursue other rights and remedies that the Law or this Contract provides.

- b. In the event this Contract is terminated as provided in paragraph 6.a., the Owner may pursue the same remedies against the Contractor as it could pursue in the event of a breach of the Contract by the Contractor.
7. Any non-resident Contractor doing business in the State of Oklahoma shall register with the Oklahoma Tax Commission, the Oklahoma Employment Security Commission, the State Industrial Court and the County Assessor of each county in which contract Work will be performed. This must be done prior to commencing Work under the Contract.
8. PAYMENT FOR MATERIAL STORED ON SITE: The following items will be required if the Contractor requests payment for material stored on the site (see Paragraph 19.b. of the General Conditions):
 - a. Invoices, approved and initialed by the consulting Engineer and the Owner, showing the quantity, size, cost, etc., of the material;
 - b. Payment will be made only for material stored in a location approved by the Owner. The storage area must provide adequate protection from the elements and the material must be stored so it can be promptly inspected. Material strung throughout the job site will not be considered properly stored.
 - c. The five percent retainer that applies to material installed will also apply to materials stored on the site;
 - d. When payment for material stored on the site is received, a paid invoice for that payment from the supplier must be submitted to the Owner prior to the payment of the next partial payment.
9. All Change Orders must be approved by the governing body of Owner or its delegated representative.
10. A final inspection will be made by the Owner before final payment is made. Final payment will not be made until the Owner certifies in writing that the construction has been completed as planned. If the Oklahoma State Department of Health or Department of Environmental Quality has issued a permit and approved the plans and specifications on this Project, they must concur in the final inspection.
12. PARTIAL OCCUPANCY AND USE: The Owner, upon advance written notification to the Contractor, shall have the right to occupy and use any completed or partially-completed portions of the Project, regardless of the percentage of completion of the entire Project, when such occupancy and use is to the Owner's best interest. Such partial occupancy and use shall be upon the following terms:
 - a. The Engineer shall inspect the portion or portions of the Project concerned and report to the Owner his findings as to the acceptability and completeness of the Work. The Engineer's report shall include a list of items to be completed or corrected before final payment.
 - b. The Owner, upon acceptance of the Engineer's report, shall give Written Notice to the Contractor of the Owner's intent to occupy and use said portions of the Project. The Owner's notice shall include a copy of the Engineer's report, shall clearly identify the portions of the Project to be occupied and used and shall establish the date of said occupancy and use.
 - c. From the date thus established, the Owner shall assume all "responsibilities for operation, maintenance and the furnishing of water, gas and electrical power for the portions of the Project thus occupied and used. The Owner shall have the right to exclude the Contractor from those portions of the Project but shall provide the Contractor with reasonable access to complete or correct necessary items of Work.
 - d. The guarantee required by the General Conditions shall not begin until completion and final acceptance of the entire Project except as to items of equipment specified, such as instrumentation, electrical and mechanical equipment, which are thus used by the Owner.

For said equipment, the warranty shall start from the date established in the written notice from the Owner.

- e. Occupancy or use of any space in the Project shall not constitute acceptance of Work not performed in accordance with the Contract or relieve the Contractor of liability to perform any Work required by the Contract but not completed at the time of said occupancy and use.
 - f. The Contractor shall not be held responsible for fair wear and tear or damage resulting from said occupancy except to the extent such damage is covered by the warranty.
 - g. The partial occupancy and use of any portion or portions of the Project by the Owner shall not constitute grounds for claims by the Contractor for release of any amounts retained from payments under the provisions of the Contract. The retained amounts will not be due until completion of the entire Project for final acceptance and final payment as set forth in the General Conditions.
13. The Contractor shall be responsible for contacting all Federal, State, County or railroad personnel required to be contacted and as set forth in any permits with respect to time schedule before commencing any Work for which a permit is required.
 14. The Contractor shall secure a cleanup release satisfactory to the Owner from any Federal, State, county or railroad agency after the Work for which a permit has been obtained has been completed.
 15. Per revisions to the Oklahoma Standards for Drug and Alcohol Testing Act effective November 1, 2011, all employers, including independent contractors, Subcontractors or employees of an independent contractor, may be subject to a workplace drug or alcohol testing policy under the terms of the contractual agreement when the drug or alcohol testing policy applies to other workers at the job site or workers who are in the same or similar classification or group.

PERFORMANCE BOND

_____, as Principal, and _____,
a corporation organized under the laws of the State of _____ as surety, are held and firmly bound unto _____ in the penal sum of _____ Dollars (\$ _____), in lawful money of the United States of America, for the payment of which, well and truly to be made, we bind ourselves and each of us, our heirs, executors, administrators, trustees, successors and assigns, jointly and severally, firmly by these presents.

The condition of this obligation is such that, whereas said Principal entered into a written contract _____ with _____ dated _____ for _____, all in compliance with the plans and specifications therefor, made a part of said contract and on file in the office of _____.

NOW, THEREFORE, if said Principal shall, in all particulars, well, truly and faithfully perform and abide by said contract and each and every covenant, condition and part thereof and shall fulfill all obligations resting upon said Principal by the terms of said contract and said specifications and if said Principal shall protect and save harmless said _____ from any pecuniary loss resulting from the breach of any of the items, covenants and conditions of said contract resting upon said Principal, then this obligation shall be null and void, otherwise to be and remain in full force and effect.

It is further expressly agreed and understood by the parties hereto that no changes or alterations in said contract and no deviations from the plan or mode of procedures herein fixed shall have the effect of releasing the sureties, or any of them, from the obligations of this Bond.

IN WITNESS WHEREOF, the said Principal has caused these presents to be executed in its name and its corporate seal to be hereunto affixed by its duly-authorized officers and the said Surety has caused these presents to be executed in its name and its corporate seal to be hereunto affixed by its Attorney-In-Fact, duly authorized to do so, the day and year set forth below.

Dated this day of _____ day of _____, _____

PRINCIPAL: _____

ATTEST: _____ By: _____

SURETY: _____

By: _____
Attorney-In-Fact

STATUTORY (PAYMENT) BOND

No. _____

We, _____, as Principal, and _____, a corporation organized under the laws of the State of _____, as Surety, are held and firmly bound unto the State of Oklahoma in the amount of _____ Dollars (\$ _____) for the payment of which we hereby bind ourselves, our heirs, executors, administrators and assigns, jointly and severally, firmly by these presents.

Dated this _____ day of _____, _____.

WHEREAS, the said _____ did on _____ enter into a certain contract with _____ for the construction of _____;

AND WHEREAS, this bond is given in compliance with Oklahoma Statutes Annotated, 194, Title 61, Sections 1 and 2, as amended;

NOW, THEREFORE, the condition of the above obligation is such that, if the Principal shall pay all indebtedness incurred for labor, materials or rental of machinery or equipment furnished in the construction of said public building or in making said public improvements, then this obligation shall be void, otherwise to remain in full force and effect.

IN WITNESS WHEREOF we have hereunto set our hands and seals the day and year first above written.

ATTEST (If by corporation)

By: _____
Bonding Company

By: _____

Attorney-In-Fact

MAINTENANCE BOND

(Defect Bond)

_____, as Principal, and _____, a corporation organized under the laws of the State of _____ and authorized to transact business in the State of Oklahoma, as Surety, are held and firmly bound unto _____,

(City, Town or Trust Authority)

in the penal sum of _____ Dollars (\$ _____) in lawful money of the United States of America, said sum being equal to one hundred percent (100%) of the Contract Price, for payment of which, well and truly to be made, we bind ourselves and each of us, our heirs, executors, administrators, trustees, successors and assigns, jointly and severally, firmly by these presents.

The condition of this obligation is such that, whereas said Principal entered into a written contract with _____

(City, Town or Trust)

dated _____, _____ for _____

_____ all in compliance with the plans and specifications thereof, made a part of said contract and on file in the office of _____

_____;

NOW, THEREFORE, if said Principal payor shall cause to be paid to _____ (City, Town or Trust Authority) all damage, loss and expense which may result by reason of defective materials and/or workmanship in connection with said work occurring within a period of one (1) year from and after the acceptance of said Project by _____, (City, Town or Trust Authority) then this obligation shall be null and void, otherwise to be and remain in full force and effect.

It is further expressly agreed and understood by the parties that no changes or alterations in said contract and no deviations from the plan or mode of procedures herein fixed shall have the effect of releasing the sureties, or any of them, from the obligations of this Bond.

IN WITNESS WHEREOF, the said Principal has caused these presents to be executed in its name and its corporate seal to be hereunto affixed by its duly authorized officers and the said Surety has caused these presents to be executed in its name and its corporate seal to be hereunto affixed by its Attorney-In-Fact, duly authorized so to do, the day and year set forth below.

Dated this _____ day of _____, _____

PRINCIPAL:

By: _____

ATTEST:

SURETY _____ By: _____

Attorney-In-Fact

INSURANCE REQUIREMENTS

Name of Insured: _____

Description of Work: _____

Location of Work: _____

<u>Kind of Insurance</u>	<u>Coverage From</u>	<u>To</u>	<u>Minimum</u>	<u>Expected Dates</u> <u>Coverage Needed</u>
Workers' Compensation	Legal Amount	_____		
General Public Liability and Property Damage, Including Vehicle Coverage:				
Bodily Injury - Each Person in One Accident	\$175,000	_____		
Bodily Injury – Two or More Persons in Any One Accident	\$1,000,000 (aggregate)	_____		
Property Damage - Each Person in Any One Accident	\$25,000	_____		
Property Damage - Aggregate Limit	\$200,000	_____		
Builder's Risk (If Required)	Full Coverage	_____		

Note: This covers all motor-driven vehicles such as cars, trucks, graders, etc.

In the event of any material change or cancellation of said policies, the company will give fifteen (15) days' written notice to _____, Owner.

Statements such as "will endeavor" and "but failure to notify Owner shall impose no obligation or liability of any kind upon the company" shall not be allowed.

Coverage shall be indicated by checking all boxes applicable. Insurance shall cover any hazards involved with the planned construction. Special coverage for blasting operations shall be listed separately on the certificates.

The Owner shall be listed as the certificate holder.

**ATTORNEY’S CERTIFICATE OF APPROVAL OF
CONTRACT AND BONDS**

I, the undersigned , the Attorney for The Rodeo Arena Interlocal Cooperative, Rogers County, Oklahoma, do hereby certify as follows:

I have examined the construction contract between _____ (“Contractor”) and the Rodeo Arena Interlocal Cooperative (“Owner”) approved by the Board of the Cooperative on _____, 20____ (“Contract”), and the surety bonds given by the Contractor in connection with the performance of said Contract including the manner of execution of the Contract and surety bonds. On the basis of the forgoing, I am of the opinion that the surety bonds are in proper form and content pursuant to the Oklahoma Public Competitive Bidding Act of 1974 and that the Contract has been duly authorized and executed by the Owner, acting through its duly authorized representatives, that said representatives have full power and authority to execute said Contract on behalf of the Owner and that the foregoing Contract constitutes a valid and legally binding obligation upon the Rodeo Arena Interlocal Cooperative enforceable in accordance with the terms, conditions and provisions thereof.

Dated this _____ day of _____, 20_____.

Attorney

Will Rogers Stampede Arena VIP Mezzanine 2025

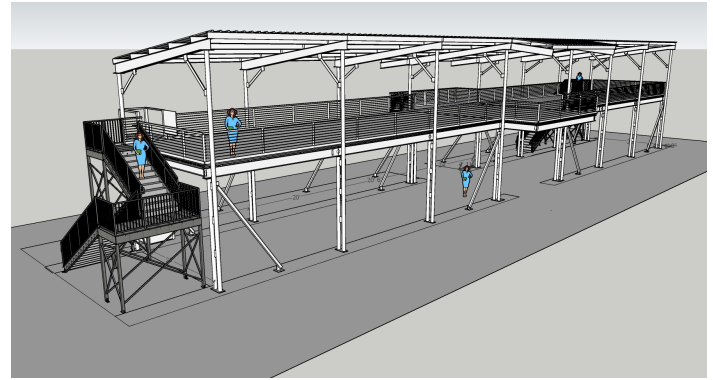
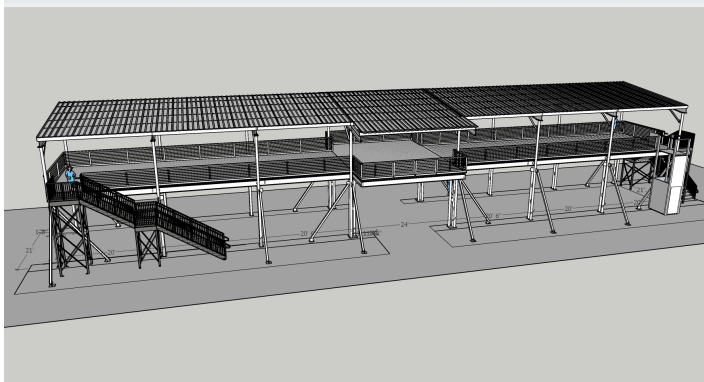

Engineering and Design
Cherry Pi Engineering LLC
5105 W. 66th St. S. Suite B
Tulsa, OK 74131
918-205-0934

Sean Wheeler, PE
Win Adams, PE

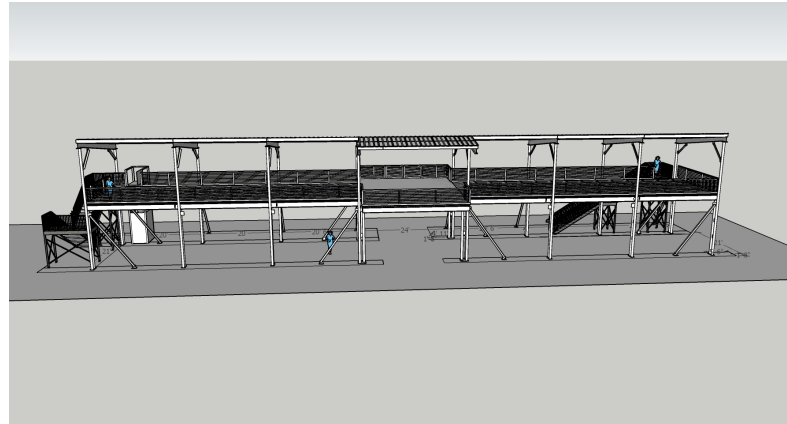
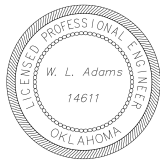

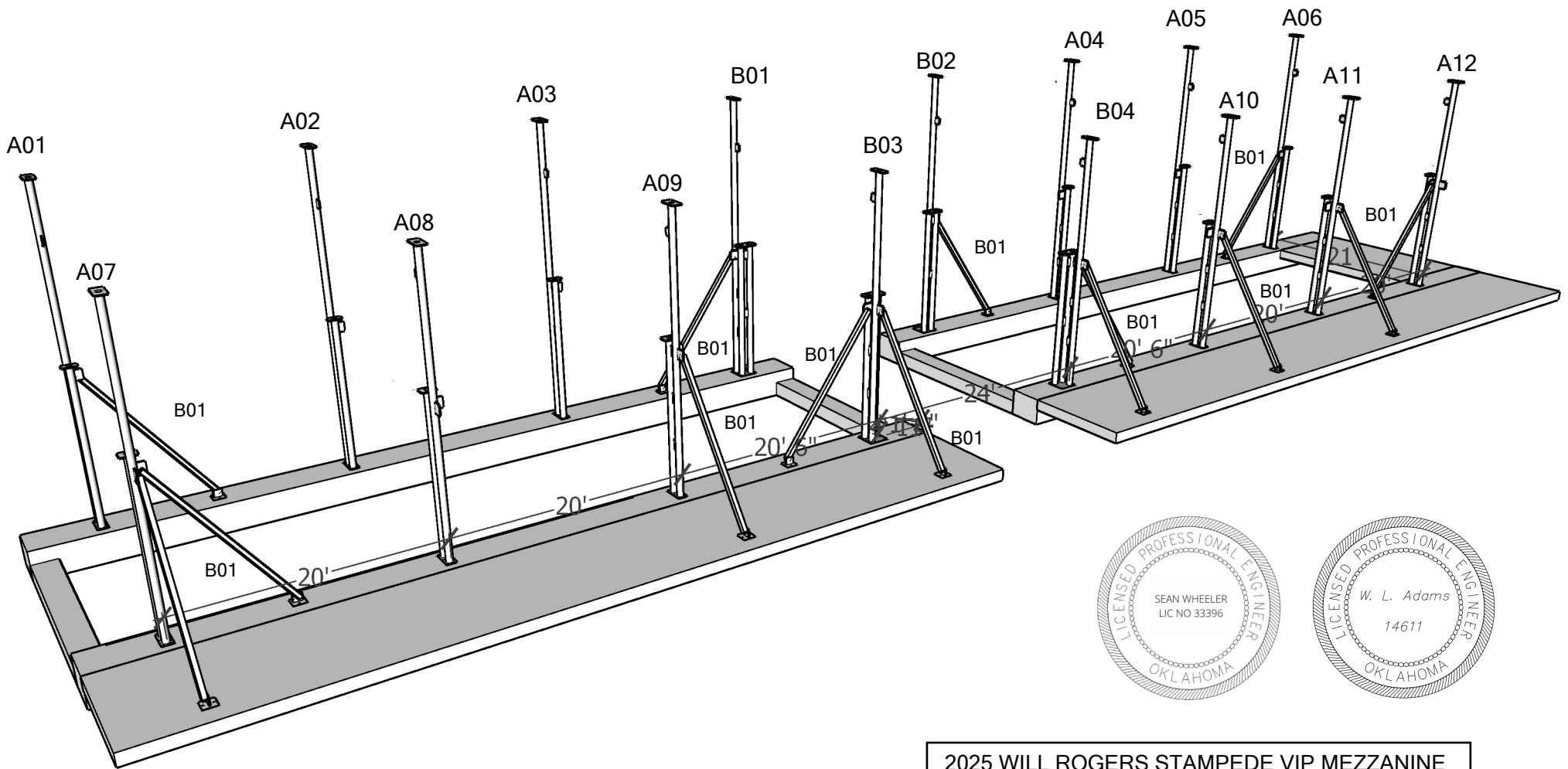

COLUMNS SHALL BE INSTALLED ON SPECIFIED ANCHOR BOLTS.
 THE SWAY BRACING SHALL BE ATTACHED TO THE CONCRETE FOOTINGS
 USING HILTI ANCHORS OR EQUAL.
 SWAY BRACE ANGLES SHALL BE WELDED TO THE COL'N SWAY PLATES.

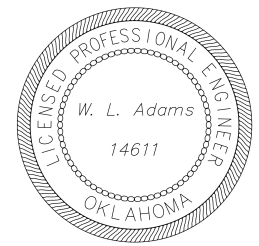

2025 WILL ROGERS STAMPEDE VIP MEZZANINE
 SHEET: 01 02 JULY 2025
 FOUNDATION WITH COLUMNS AND SWAY BRACES

FOOTING/FOUNDATION WRS ARENA 2025 VIP MEZZ

REBAR AND ANCHOR BOLT DETAILS SHOWN ON SHEET 05 & SHEET 06.
 CONCRETE SHALL BE 4,000PSI WITH PLASTISIZER.
 CONCRETE SHALL BE PLACED UPON SOLID SUBSURFACE WITH 6" OF 1 1/2" CLASS A ROCK.
 SURFACE FINISH SHALL BE BROOM FINISH.

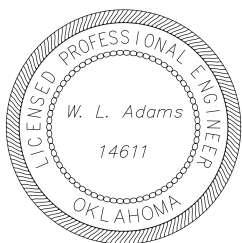
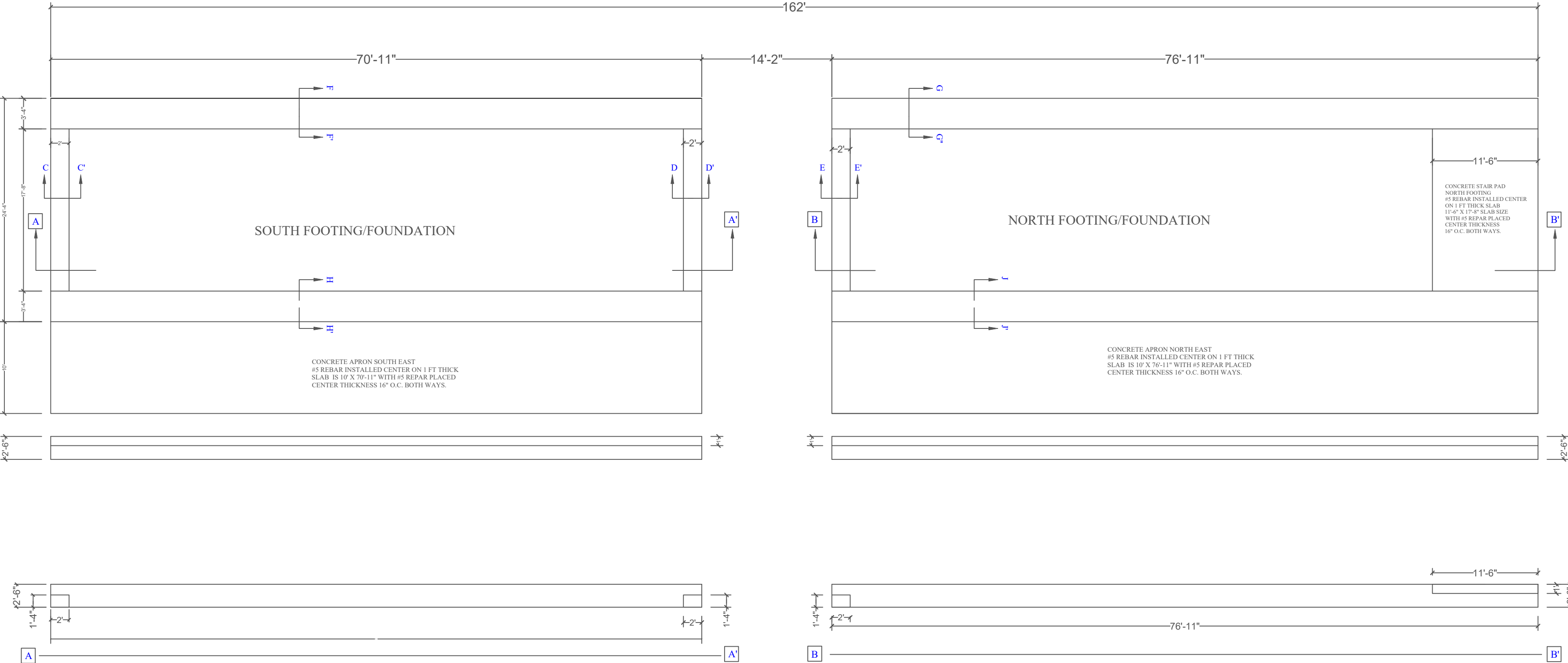

NORTH
 SHEET: 02

CHERRY PI ENGINEERING, LLC
 5105 W. 66TH ST. S. SUITE B
 TULSA, OK 74131
 918-205-0934

PROJECT: WIL ROGERS STAMPEDE ARENA VIP MEZZ. 2025
 DRAWING: MEZZ FOOTING DETAILS
 SHEET: 02
 DATE: 06/29/2025 BY: WLA

**ANCHOR BOLT DETAILS AND LOCATION
SOUTH FOOTING**

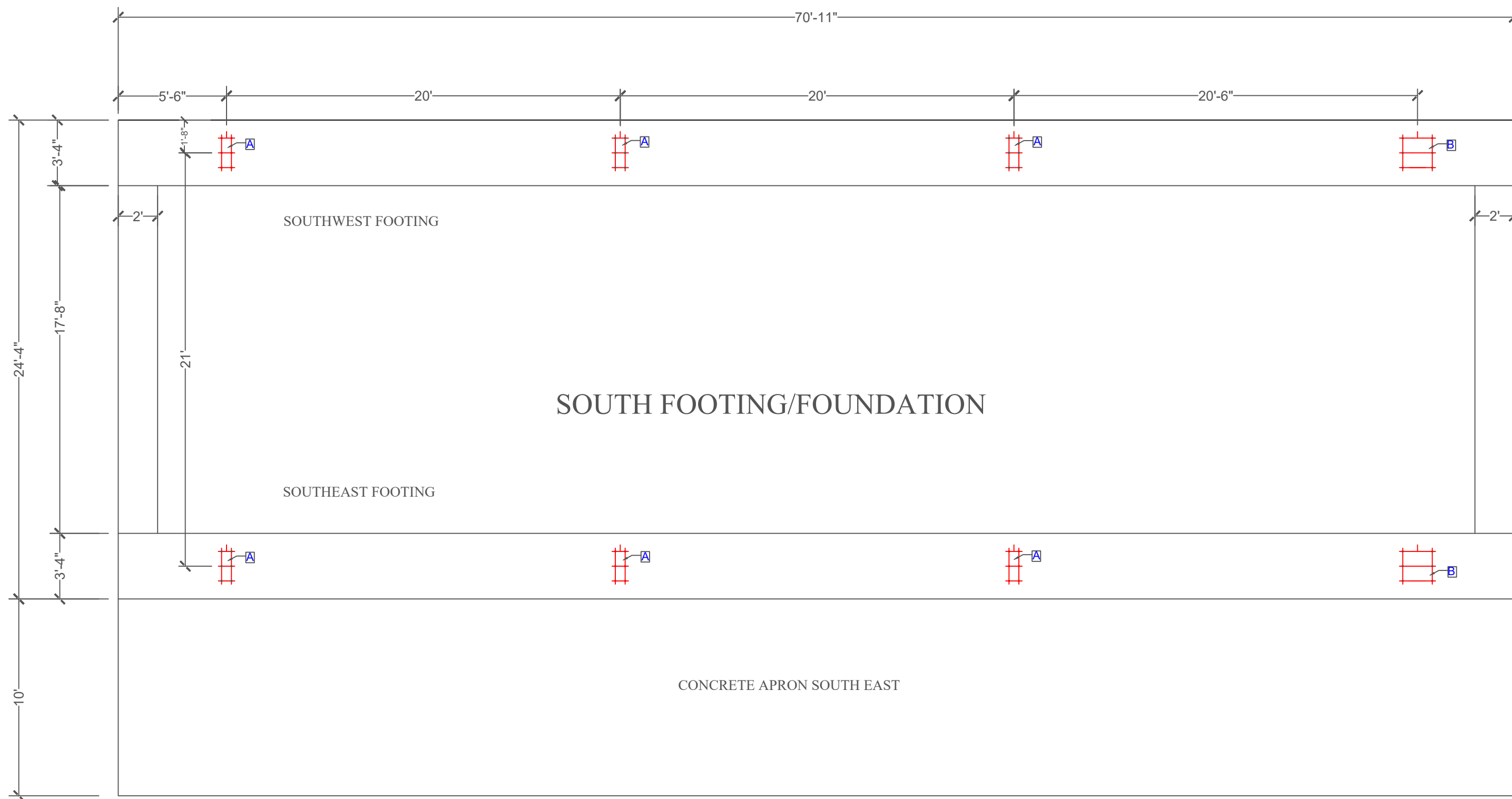

SEE SHEET 05 FOR ANCHOR BOLT SPECIFICATIONS

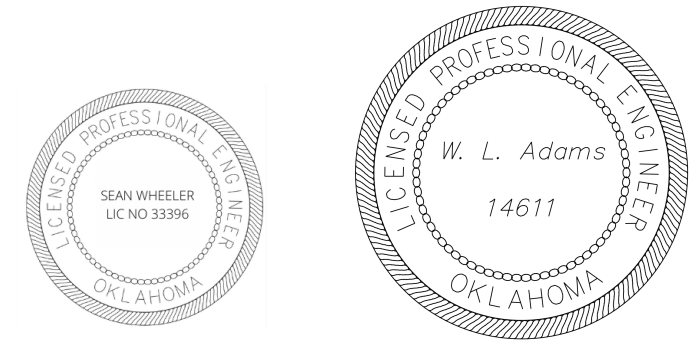

NORTH →

SHEET: 03

CHERRY PI ENGINEERING, LLC
5105 W. 66TH ST. S. SUITE B
TULSA, OK 74131
918-205-0934

PROJECT: WIL ROGERS STAMPEDE ARENA VIP MEZZ. 2025
DRAWING: MEZZ FOOTING DETAILS
SHEET: 03
DATE: 06/29/2025 BY: WLA

**ANCHOR BOLT DETAILS AND LOCATION
NORTH FOOTING**

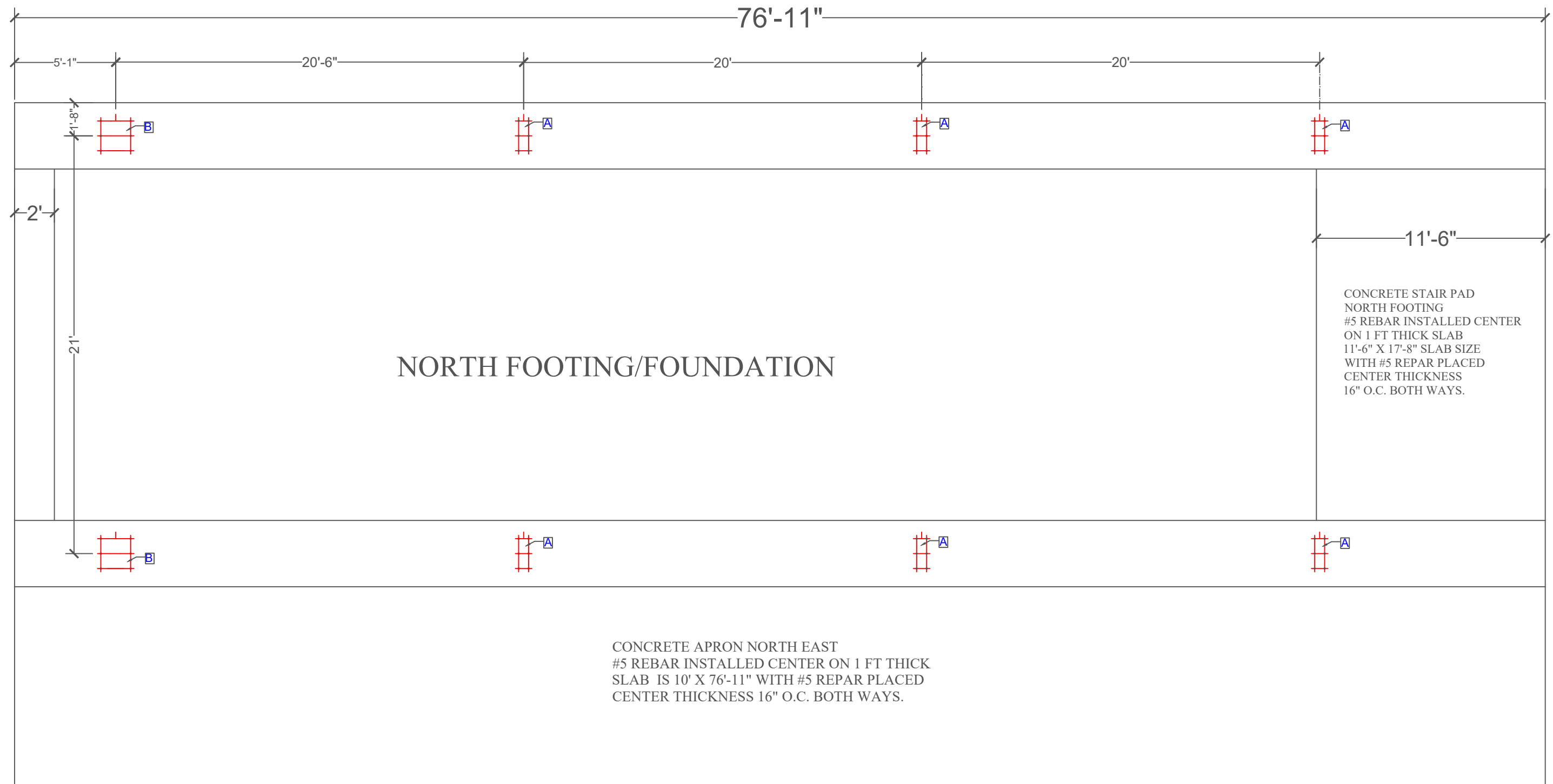

SEE SHEET 05 FOR ANCHOR BOLT SPECIFICATIONS

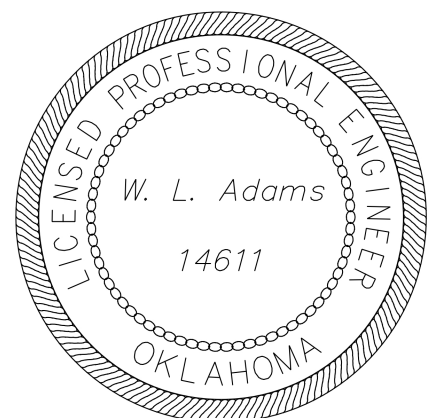

NORTH →

SHEET: 04

<p>CHERRY PI ENGINEERING, LLC 5105 W. 66TH ST. S. SUITE B TULSA, OK 74131 918-205-0934</p>	<p>PROJECT: WIL ROGERS STAMPEDE ARENA VIP MEZZ. 2025 DRAWING: MEZZ FOOTING DETAILS SHEET: 04 DATE: 06/29/2025 BY: WLA</p>
--	---

B STYLE BASE PLATE PATTERN

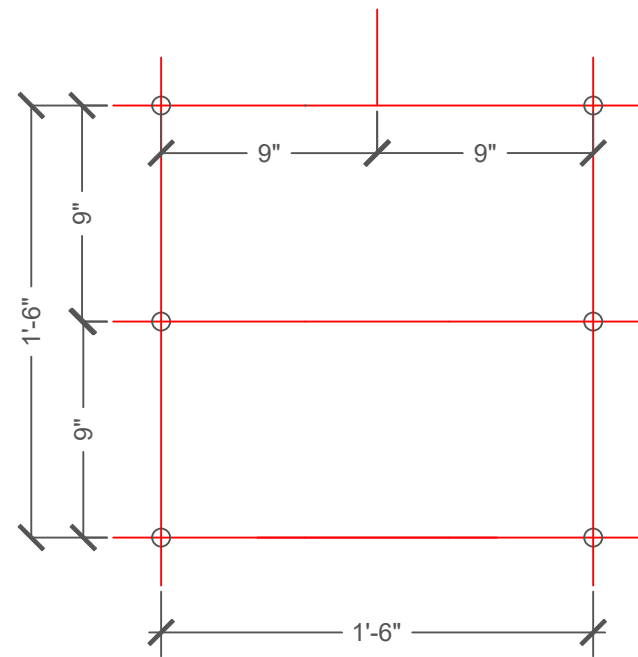

A STYLE BASE PLATE PATTERN

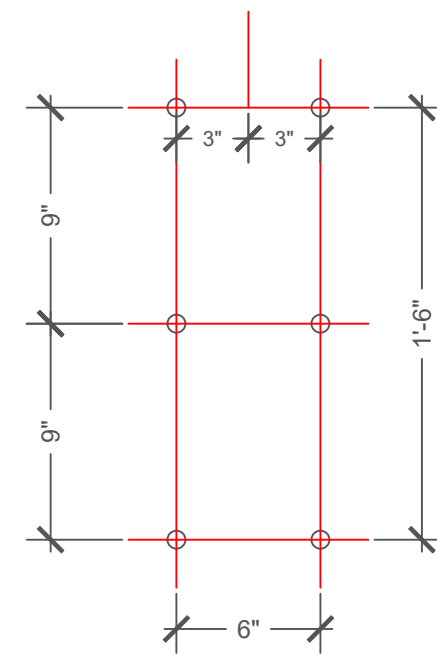

ANCHOR BOLTS SHALL BE F1554 CR 36
 $\frac{3}{4}$ X 24 X 4 X 6
 3/4" DIA. 24" LENGTH 4" HOOK 6" THREADS
 QTY: 96

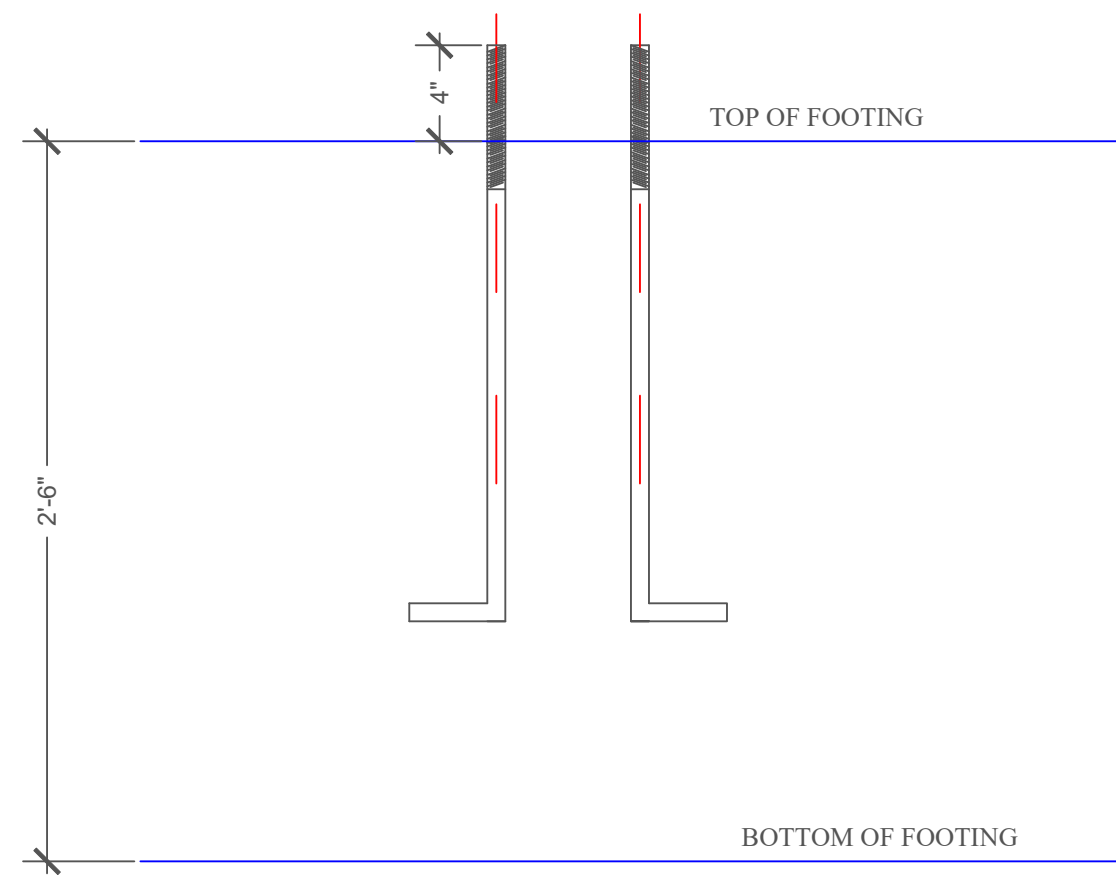
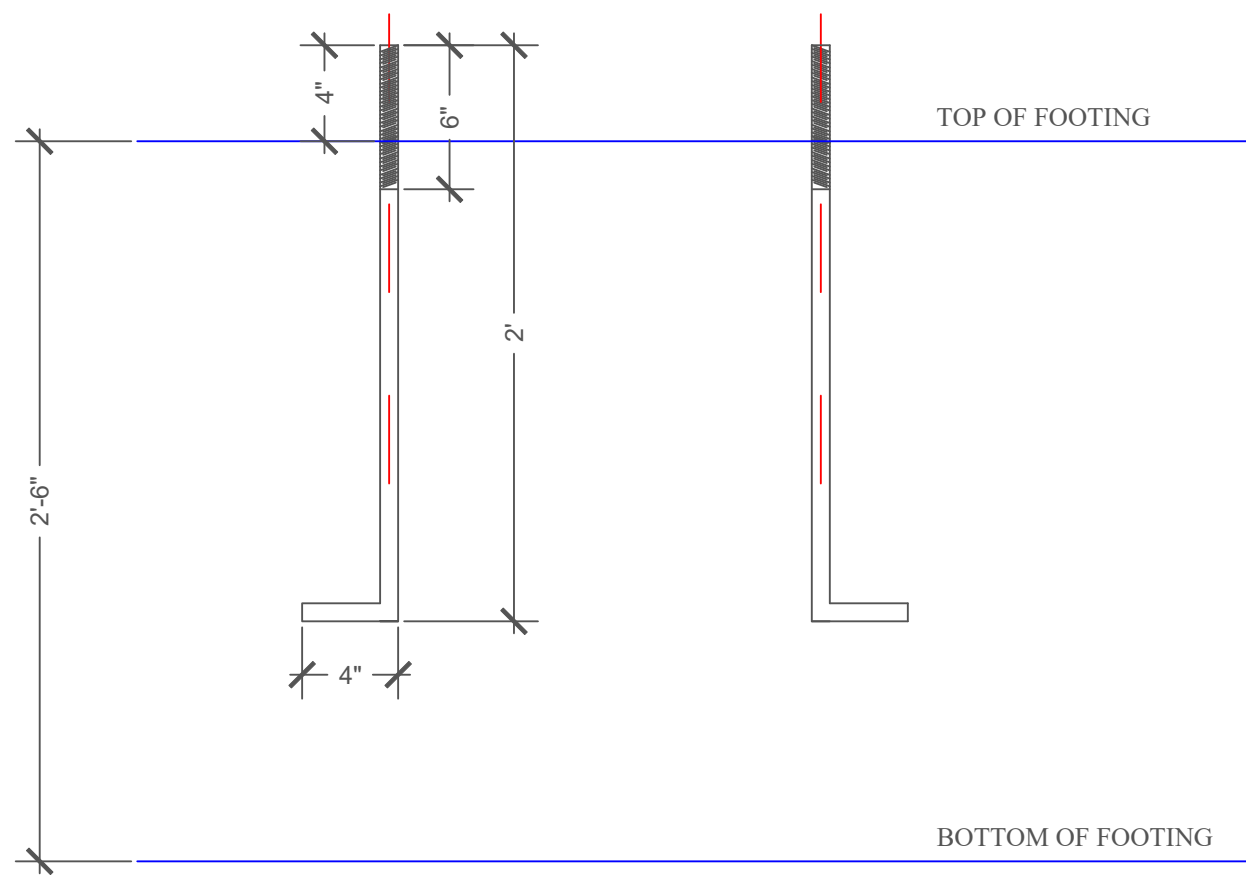

ANCHOR BOLT SPACING DETAIL



SHEET: 05

CHERRY PI ENGINEERING, LLC 5105 W. 66TH ST. S. SUITE B TULSA, OK 74131 918-205-0934	PROJECT: WIL ROGERS STAMPEDE ARENA VIP MEZZ. 2025 DRAWING: MEZZ FOOTING DETAILS SHEET: 05 DATE: 07/10/2025 BY: WIN ADAMS
--	---



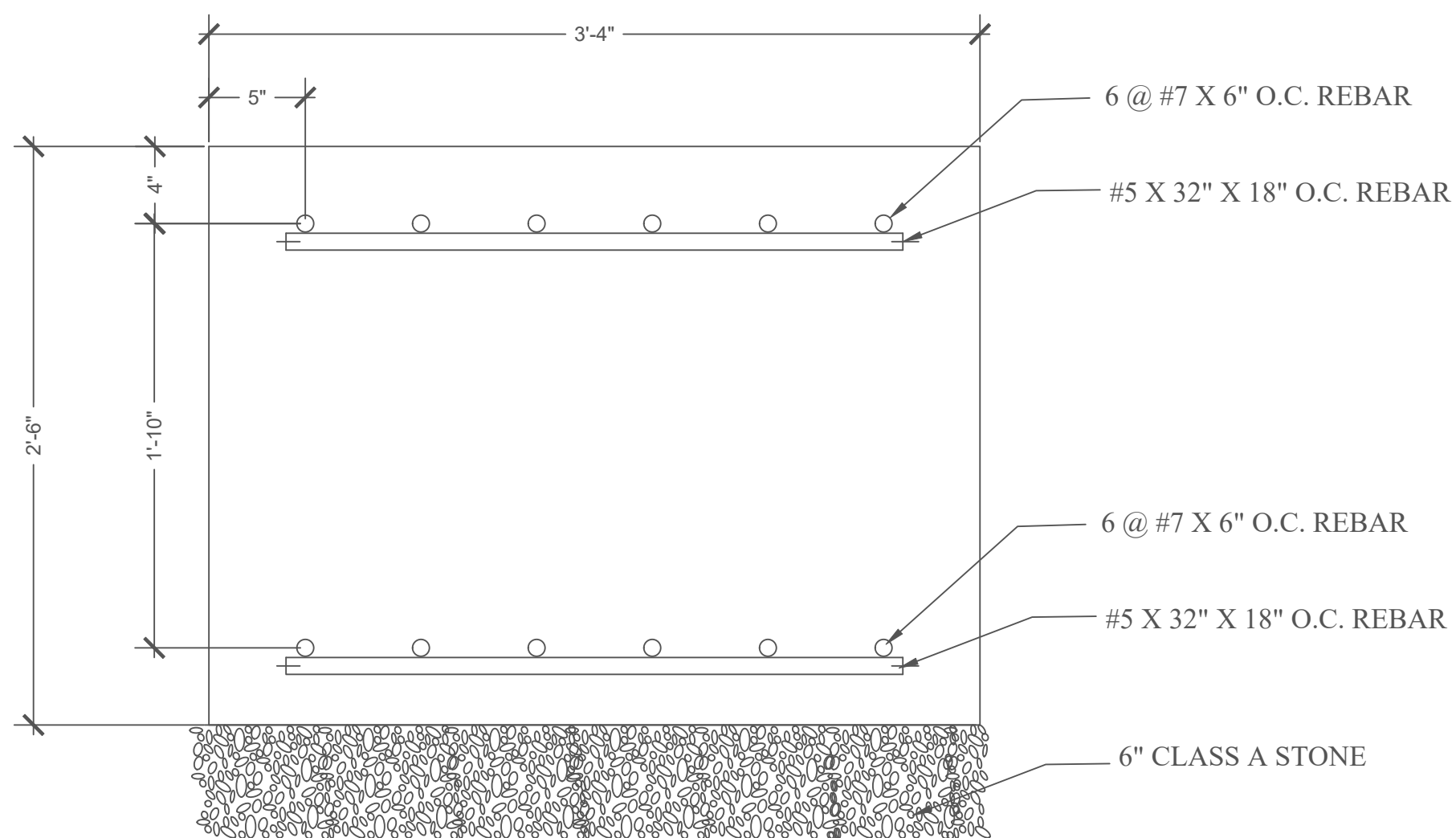

F ————— F'

G ————— G'

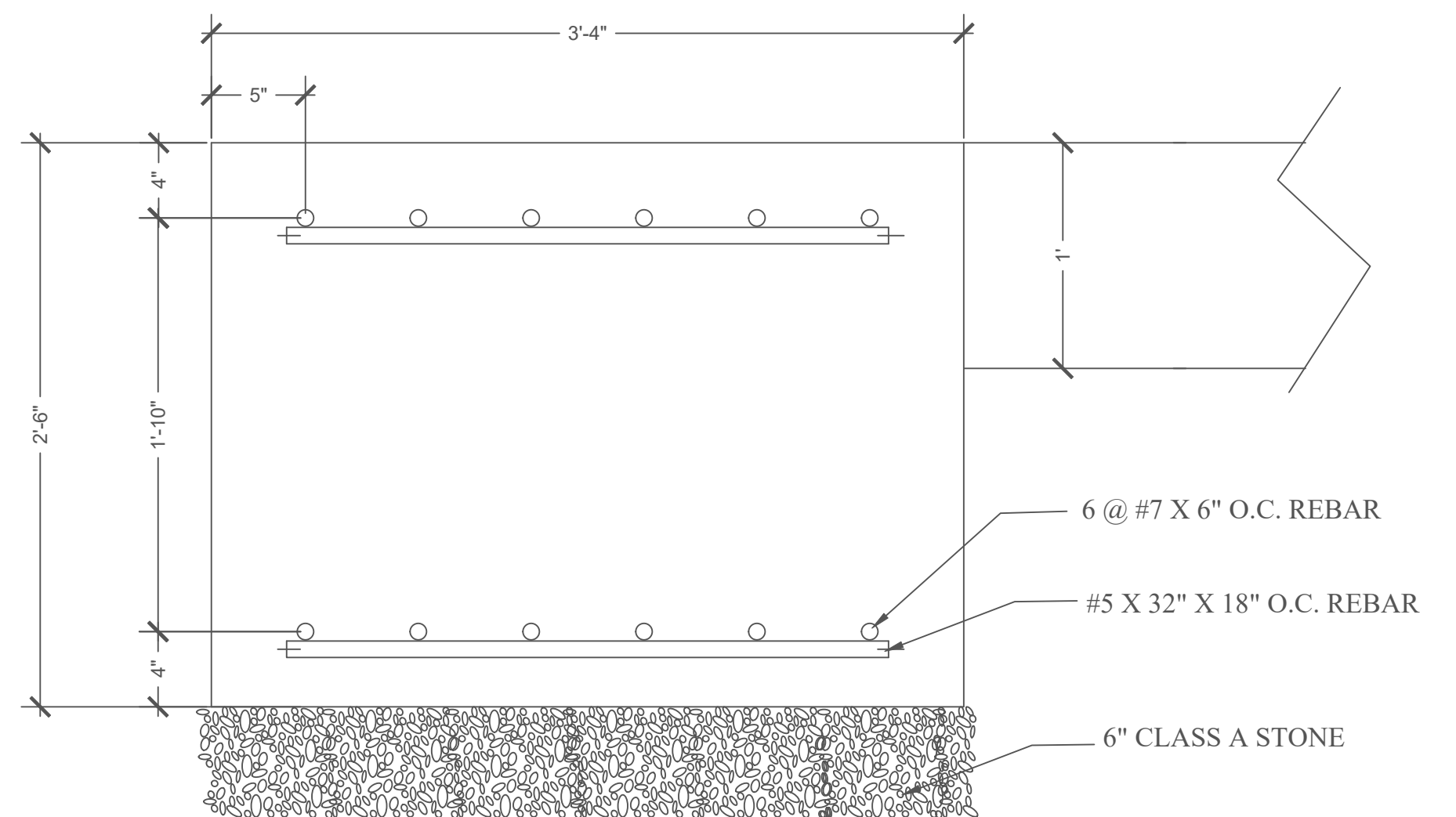

J ————— J'

H ————— H'

REBAR DETAIL FOR FOOTINGS

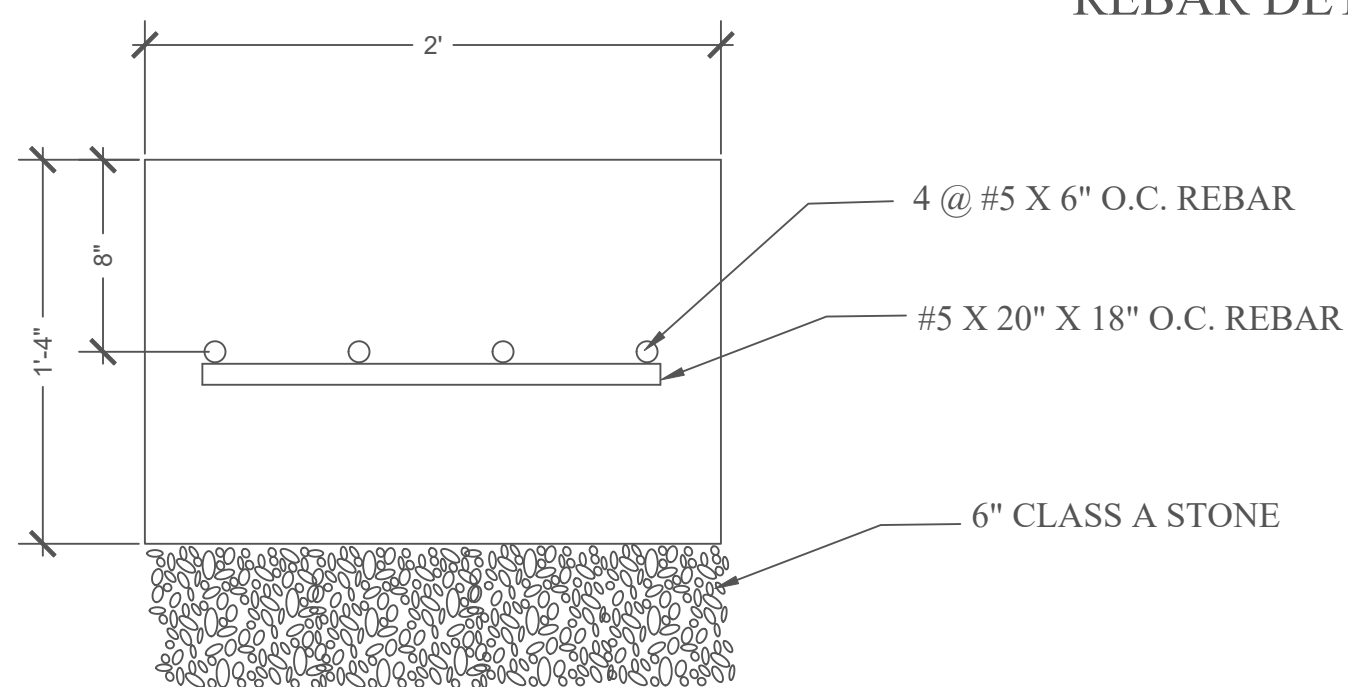

C ————— C'

D ————— D'

E ————— E'

4,000 PSI CONCRETE PLACED UPON 6" OF 1 1/2" CLASS A STONE.

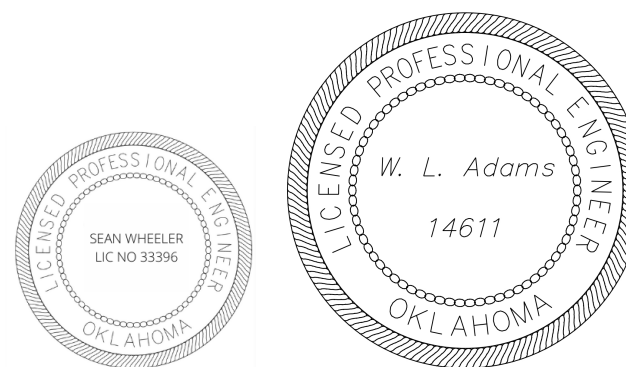

SHEET: 06

CHERRY PI ENGINEERING, LLC
5105 W. 66TH ST. S. SUITE B
TULSA, OK 74131
918-205-0934

PROJECT: WIL ROGERS STAMPEDE ARENA VIP MEZZ. 2025
DRAWING: MEZZ FOOTING DETAILS
SHEET: 06
DATE: 07/10/2025 BY: WIN ADAMS

COL'N NUMBERS OF IDENTICAL COL'NS			
A01	A04	A07	A10
A02	A05	A08	A11
A03	A06	A09	A12
B01	B02	B03	B04

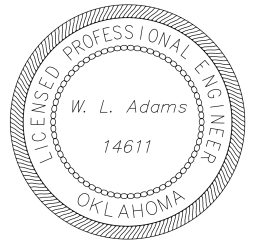
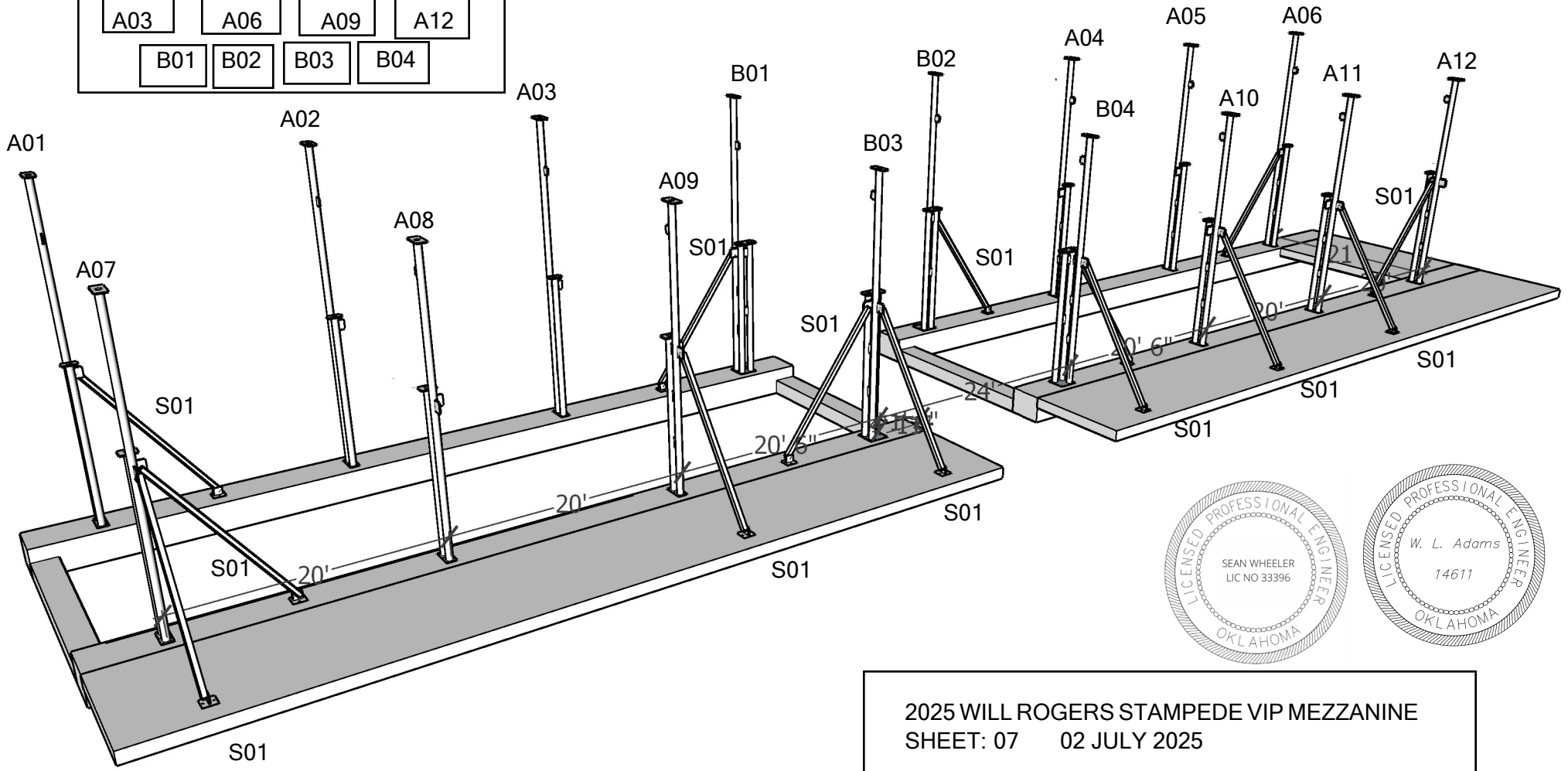

2025 WILL ROGERS STAMPEDE VIP MEZZANINE
 SHEET: 07 02 JULY 2025

FOUNDATION WITH COLUMNS & SWAY BRACES

SHEET: 07

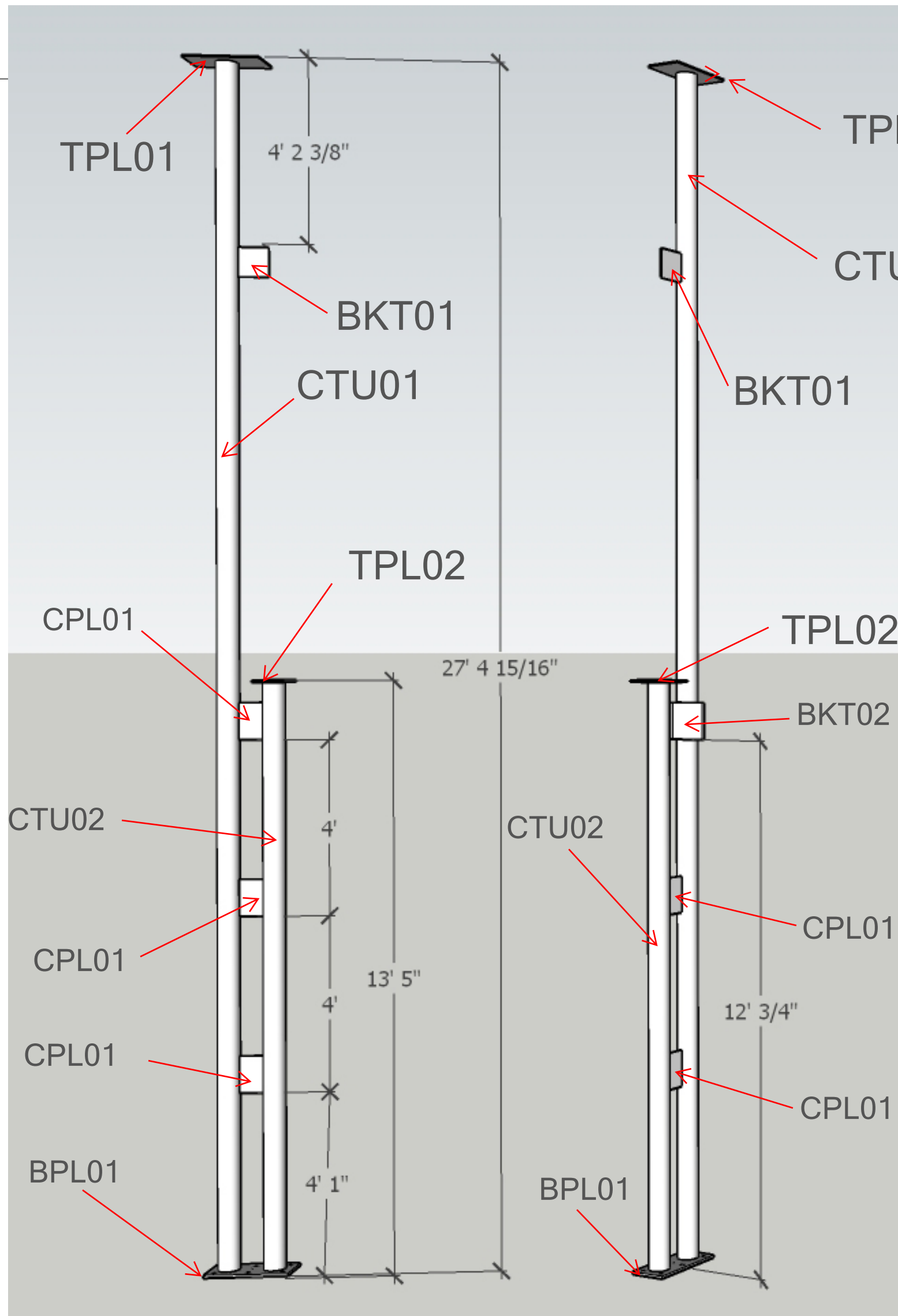

INDIVIDUAL COMPONENT DETAILS CAN BE FOUND ON SHEET 16.
 QTYS REQUIRED FOR COL'NS A01,A02,A03:

- TPL01- 3 EA
- BPL01- 3 EA
- BKT01- 3 EA
- CTU01- 3 EA.
- BKT02- 3 EA
- TPL02- 3 EA
- CPL01- 9 EA
- CTU02- 3 EA

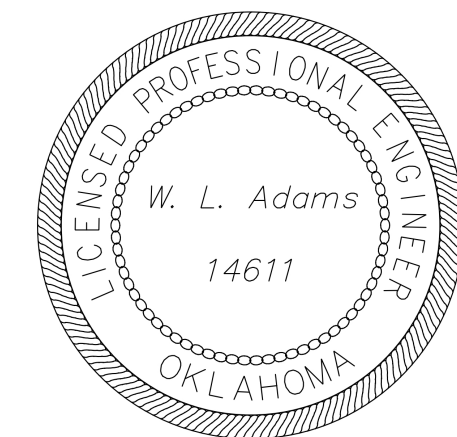

MAIN COLUMNS A01-A02-A03

SHEET: 08

CHERRY PI ENGINEERING, LLC
 5105 W. 66TH ST. S. SUITE B
 TULSA, OK 74131
 918-205-0934

PROJECT: WIL ROGERS STAMPEDE ARENA VIP MEZZ. 2025
 DRAWING: MAIN COL'NS A01 A02 A03
 SHEET: 08
 DATE: 07/10/2025 BY: WIN ADAMS

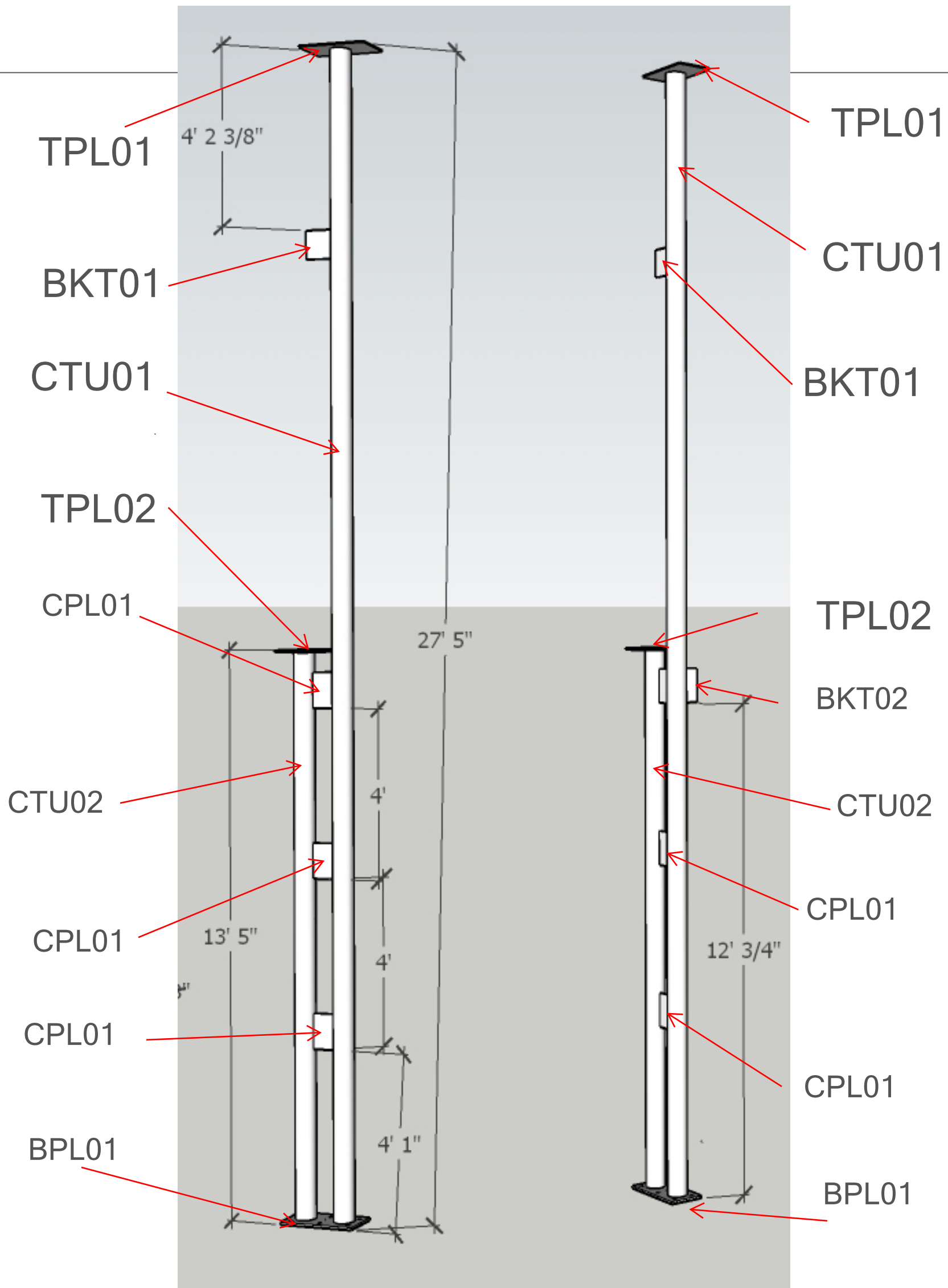

INDIVIDUAL COMPONENT DETAILS CAN BE FOUND ON SHEET 16.
 QTYS REQUIRED FOR COL'NS A04,A05,A06:

- TPL01- 3 EA
- BPL01- 3 EA
- BKT01- 3 EA
- CTU01- 3 EA.
- CPL02- 3 EA
- BKT02- 3 EA
- TPL02- 3 EA
- CPL01- 9 EA
- CTU02- 3 EA

MAIN COLUMNS A04-A05-A06

SHEET: 09

CHERRY PI ENGINEERING, LLC
 5105 W. 66TH ST. S. SUITE B
 TULSA, OK 74131
 918-205-0934

PROJECT: WIL ROGERS STAMPEDE ARENA VIP MEZZ. 2025
 DRAWING: MAIN COL'NS A04 A05 A06
 SHEET: 09
 DATE: 07/10/2025 BY: WIN ADAMS

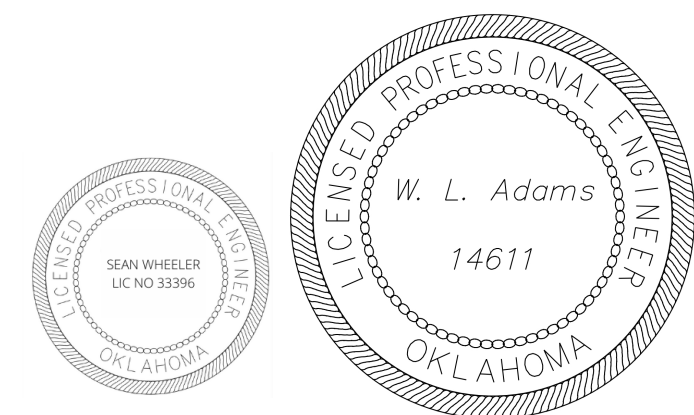

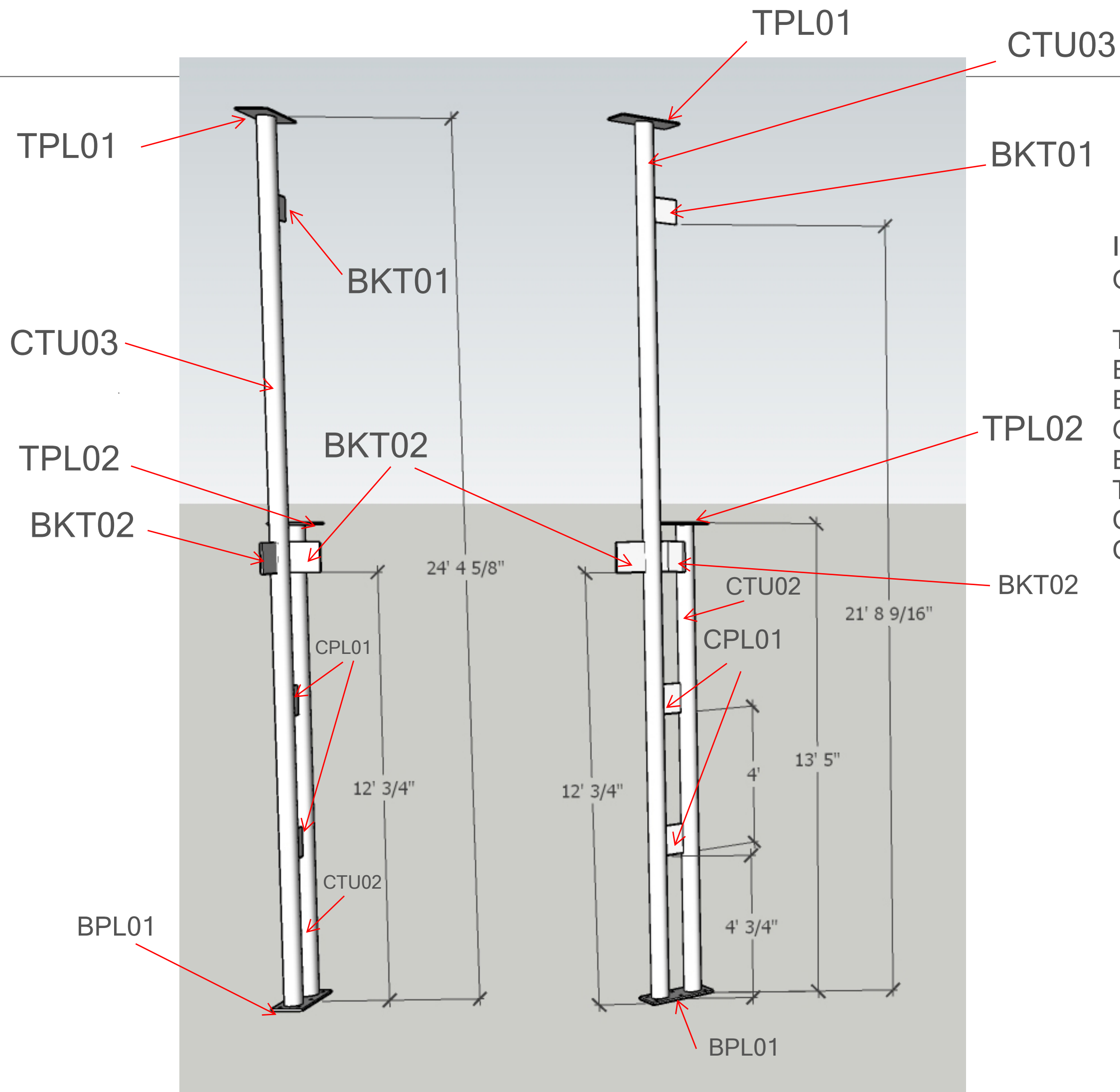

INDIVIDUAL COMPONENT DETAILS CAN BE FOUND ON SHEET 16.
 QTYS REQUIRED FOR COL'NS A07,A08,A09:

- TPL01- 3 EA
- BPL01- 3 EA
- BKT01- 3 EA
- CTU03- 3 EA.
- BKT02- 6 EA
- TPL02- 3 EA
- CPL01- 9 EA
- CTU02- 3 EA

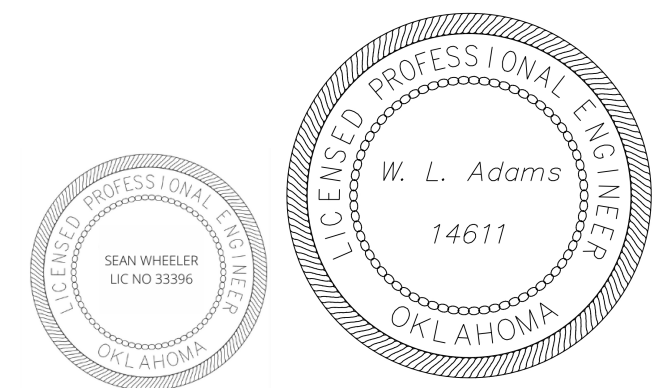

MAIN COLUMNS A07-A08-A09

SHEET: 10

CHERRY PI ENGINEERING, LLC
 5105 W. 66TH ST. S. SUITE B
 TULSA, OK 74131
 918-205-0934

PROJECT: WIL ROGERS STAMPEDE ARENA VIP MEZZ. 2025
 DRAWING: MAIN COL'NS A07 A08 A09
 SHEET: 10
 DATE: 07/10/2025 BY: WIN ADAMS

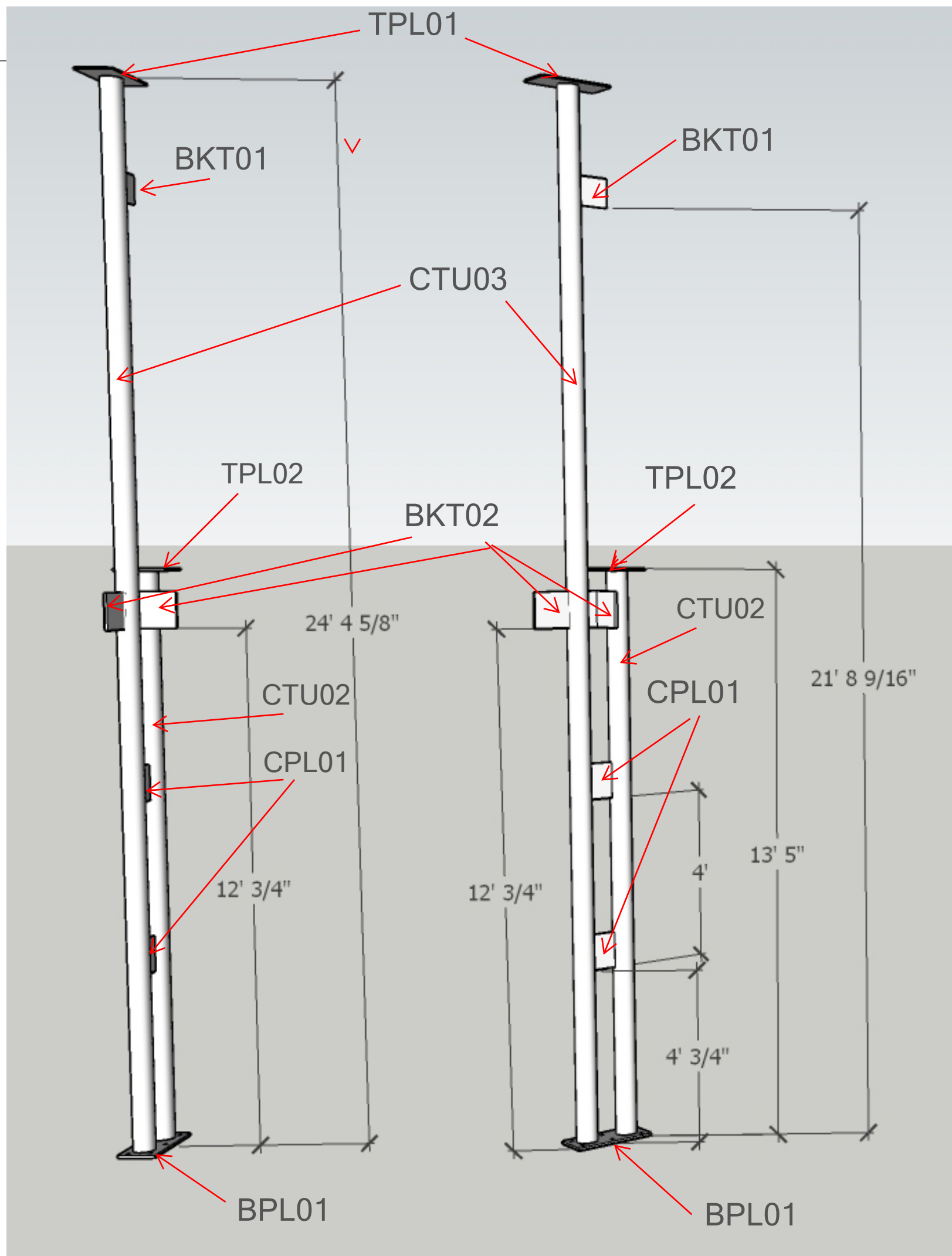

INDIVIDUAL COMPONENT DETAILS CAN BE FOUND ON SHEET 16.

QTY'S REQUIRED FOR COL'NS A10,A11,A12:

- TPL01- 3 EA
- BPL01- 3 EA
- BKT01- 3 EA
- CTU03- 3 EA.
- BKT02- 6 EA
- TPL02- 3 EA
- CPL01- 9 EA
- CTU02- 3 EA

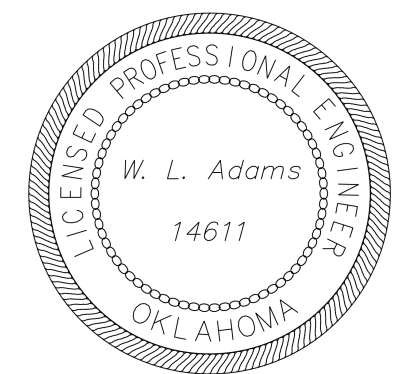

MAIN COLUMNS A10-A11-A12

SHEET: 11

CHERRY PI ENGINEERING, LLC
 5105 W. 66TH ST. S. SUITE B
 TULSA, OK 74131
 918-205-0934

PROJECT: WIL ROGERS STAMPEDE ARENA VIP MEZZ. 2025
 DRAWING: MAIN COL'NS A10 A11 A12
 SHEET: 11
 DATE: 07/10/2025 BY: WIN ADAMS

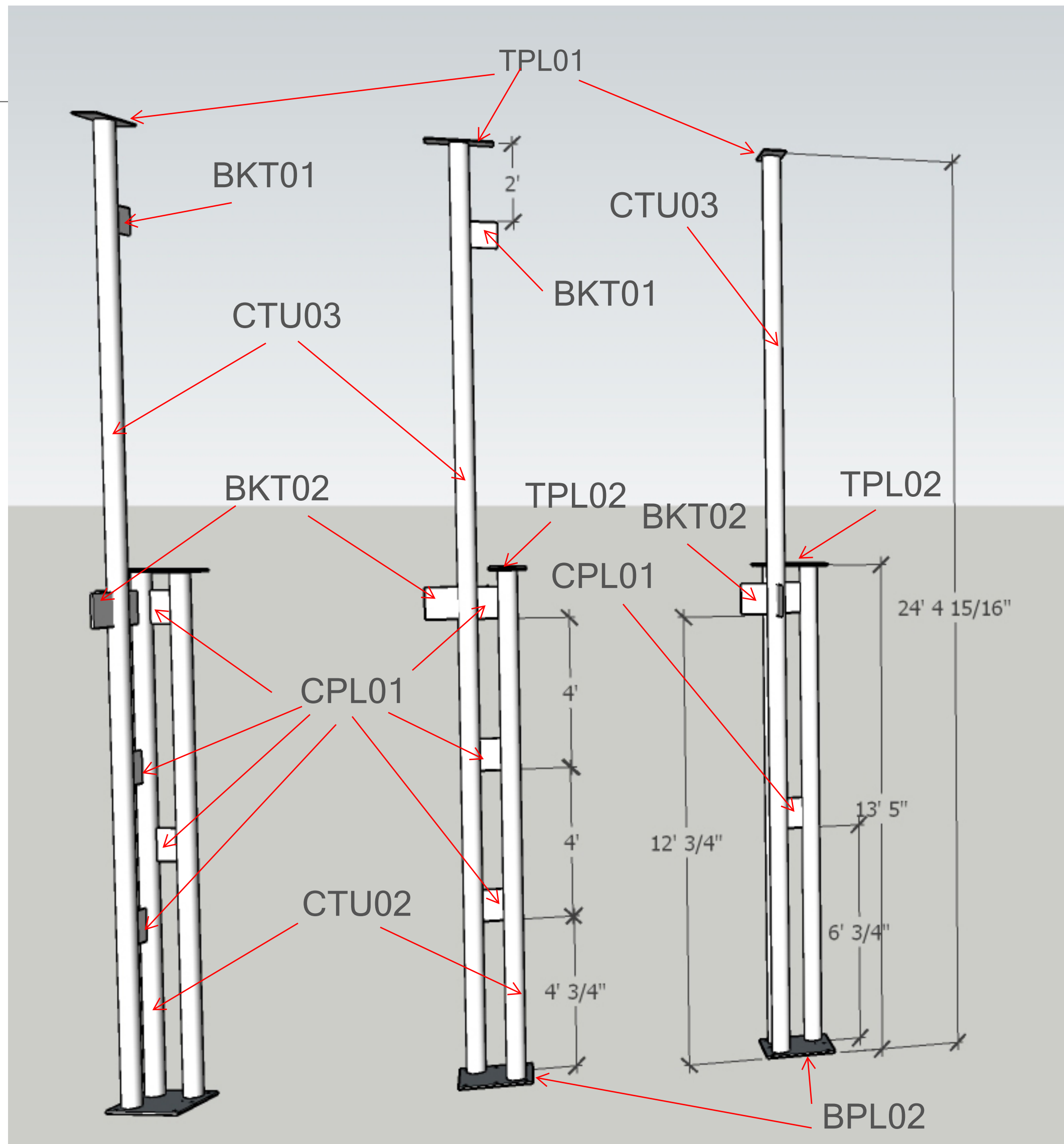

INDIVIDUAL COMPONENT DETAILS CAN BE FOUND ON SHEET 16.
 QTYS REQUIRED FOR COL'N B03:

- TPL01- 1 EA
- BPL02- 1EA
- BKT01-1 EA
- CTU03- 1EA.
- BKT02- 2 EA
- TPL02- 1 EA
- CPL01- 5 EA
- CTU02- 2 EA

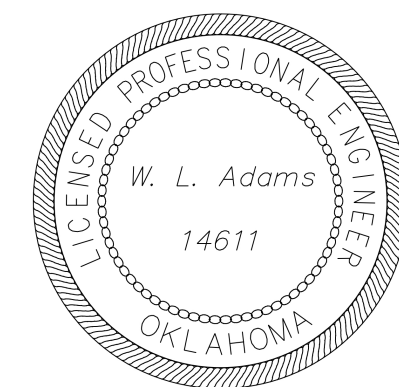

MAIN COLUMN B03 SHOWN IN THREE VIEWS

SHEET: 12

CHERRY PI ENGINEERING, LLC
 5105 W. 66TH ST. S. SUITE B
 TULSA, OK 74131
 918-205-0934

PROJECT: WIL ROGERS STAMPEDE ARENA VIP MEZZ. 2025
 DRAWING: MAIN COL'NS B03
 SHEET: 12
 DATE: 07/10/2025 BY: WIN ADAMS

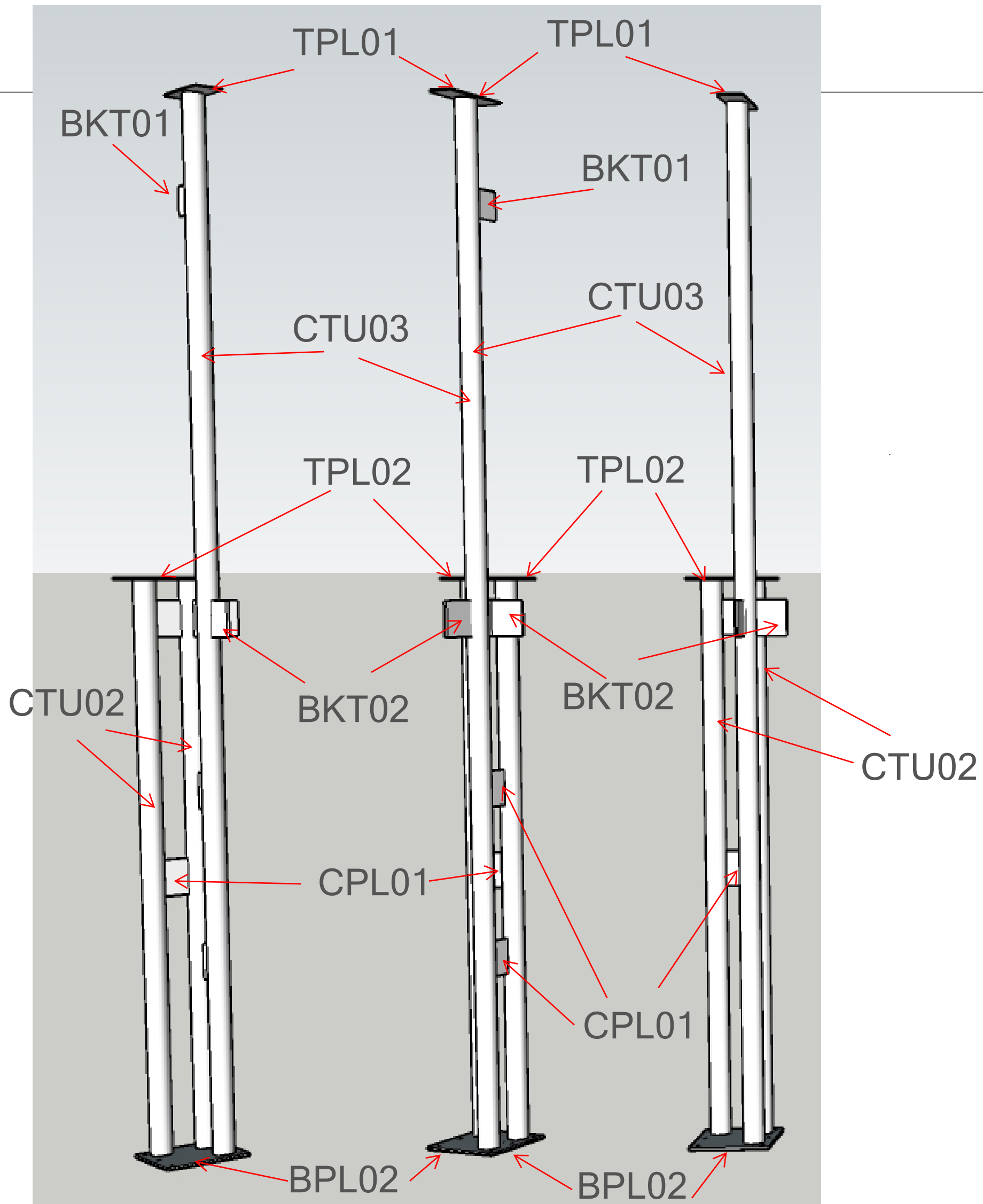

INDIVIDUAL COMPONENT DETAILS CAN BE FOUND ON SHEET 16.
 QTYS REQUIRED FOR COL'N B04:

- TPL01- 1 EA
- BPL02- 1EA
- BKT01-1 EA
- CTU03- 1EA.
- BKT02- 1 EA
- TPL02- 1 EA
- CPL01- 5 EA
- CTU02- 2 EA

MAIN COLUMN B04 SHOWN IN THREE VIEWS

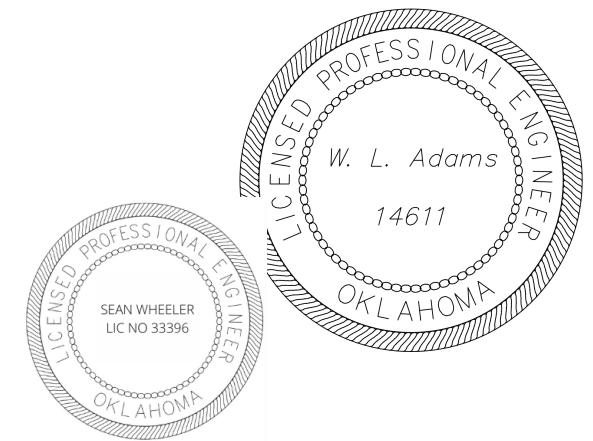

SHEET: 13

CHERRY PI ENGINEERING, LLC
 5105 W. 66TH ST. S. SUITE B
 TULSA, OK 74131
 918-205-0934

PROJECT: WIL ROGERS STAMPEDE ARENA VIP MEZZ. 2025
 DRAWING: MAIN COL'NS B04
 SHEET: 13
 DATE: 07/10/2025 BY: WIN ADAMS

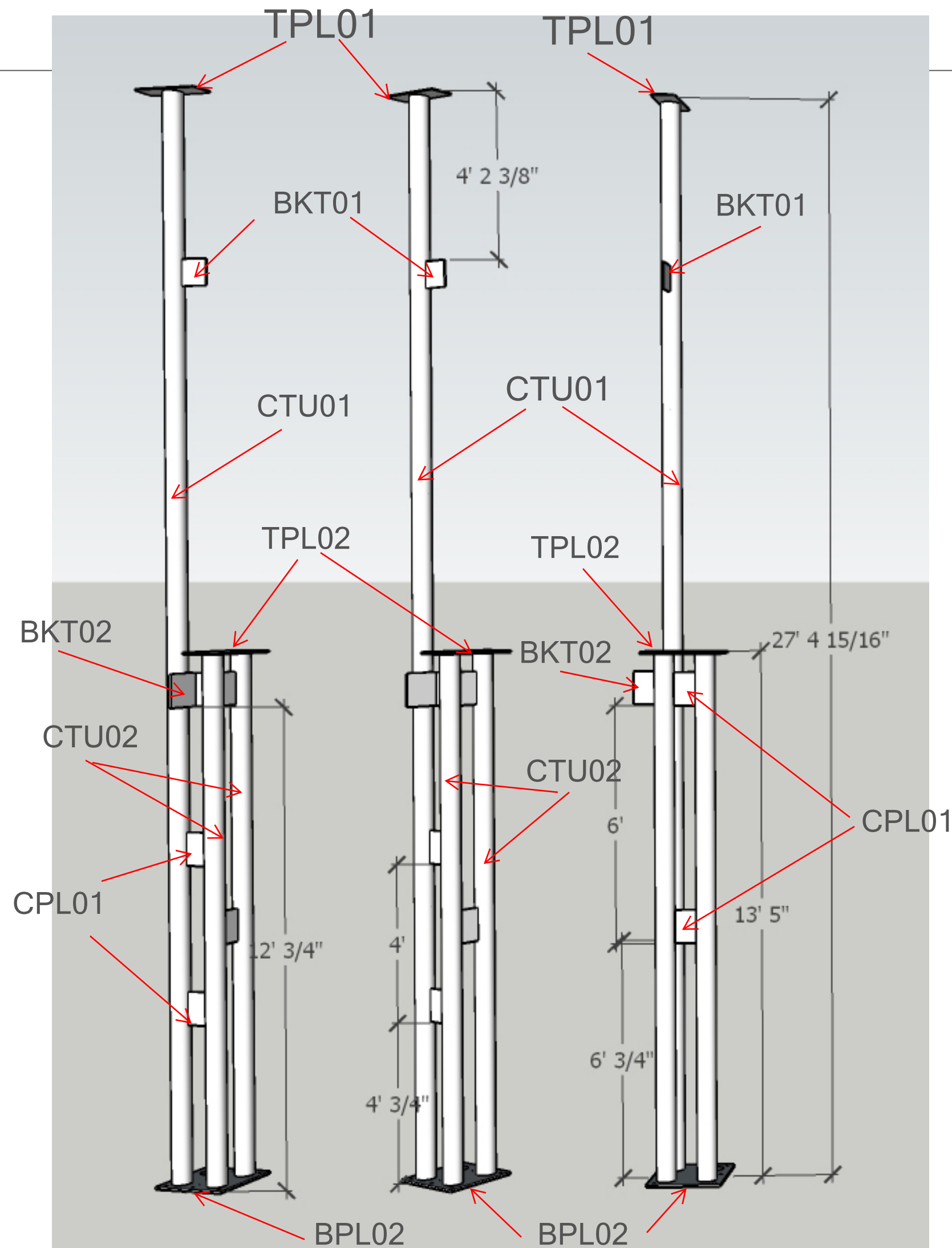

INDIVIDUAL COMPONENT DETAILS CAN BE FOUND ON SHEET 16.
 QTY'S REQUIRED FOR COL'N B01:

- TPL01- 1 EA
- BPL02- 1EA
- BKT01-1 EA
- CTU01- 1EA.
- BKT02- 1 EA
- TPL02- 1 EA
- CPL01- 5 EA
- CTU02- 2 EA

MAIN COLUMN B01 SHOWN IN THREE VIEWS

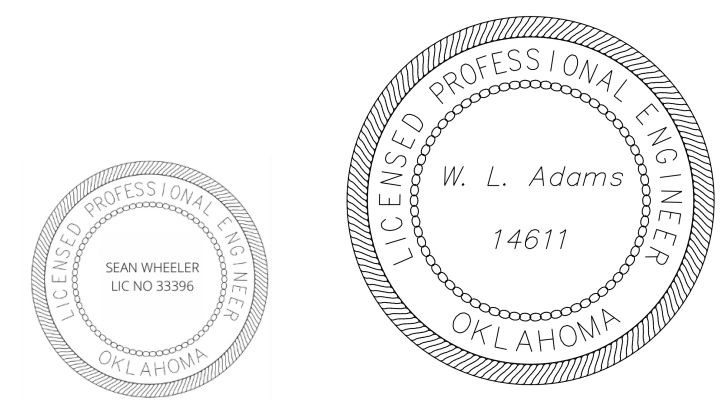

SHEET: 14

<p>CHERRY PI ENGINEERING, LLC 5105 W. 66TH ST. S. SUITE B TULSA, OK 74131 918-205-0934</p>	<p>PROJECT: WIL ROGERS STAMPEDE ARENA VIP MEZZ. 2025 DRAWING: MAIN COL'NS B01 SHEET: 14 DATE: 07/10/2025 BY: WIN ADAMS</p>
---	---

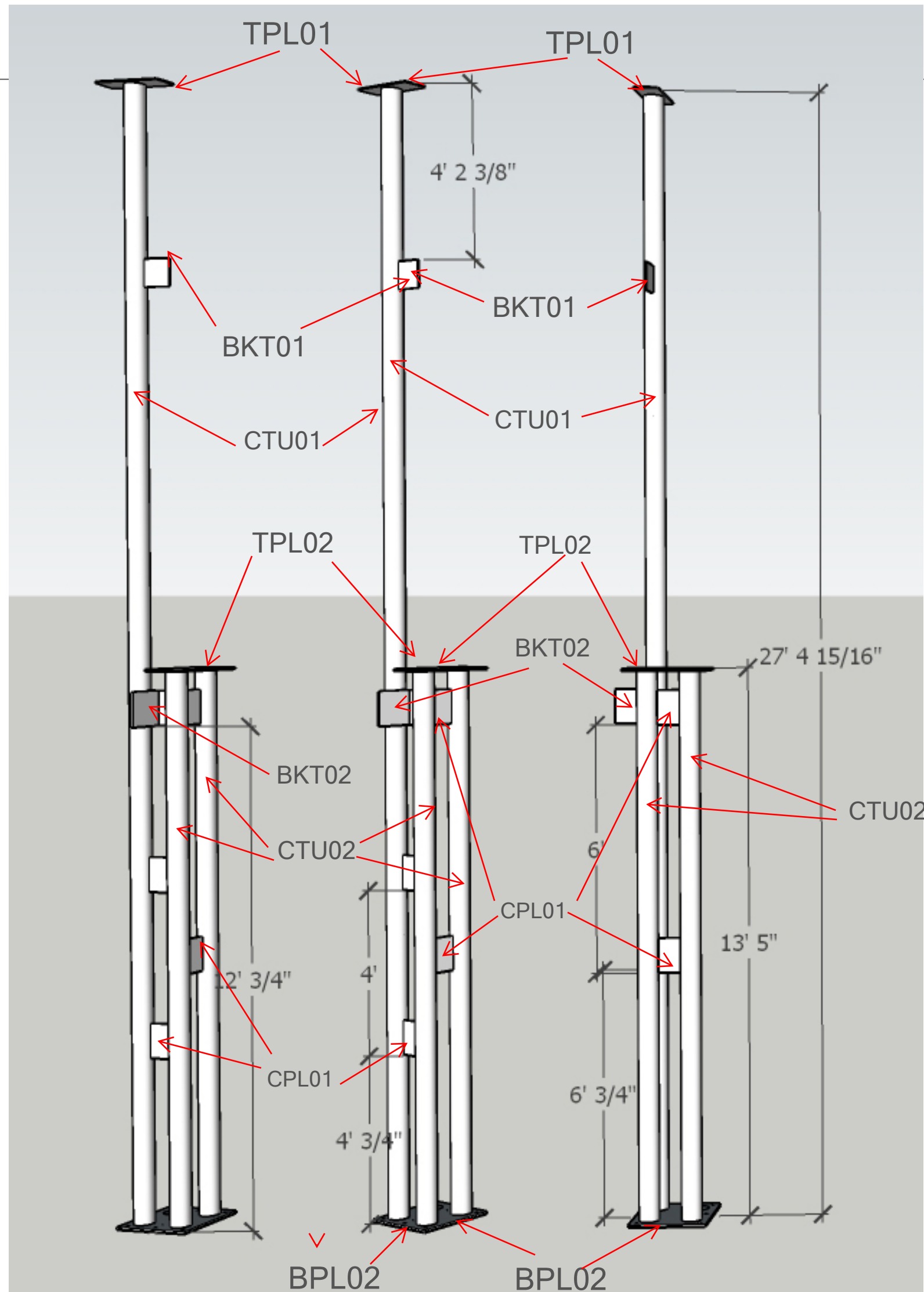

INDIVIDUAL COMPONENT DETAILS CAN BE FOUND ON SHEET 16.
 QTY'S REQUIRED FOR COL'N B02:

- TPL01- 1 EA
- BPL02- 1EA
- BKT01-1 EA
- CTU01- 1EA.
- BKT02- 1 EA
- TPL02- 1 EA
- CPL01- 5 EA
- CTU02- 2 EA

MAIN COLUMN B02 SHOWN IN THREE VIEWS

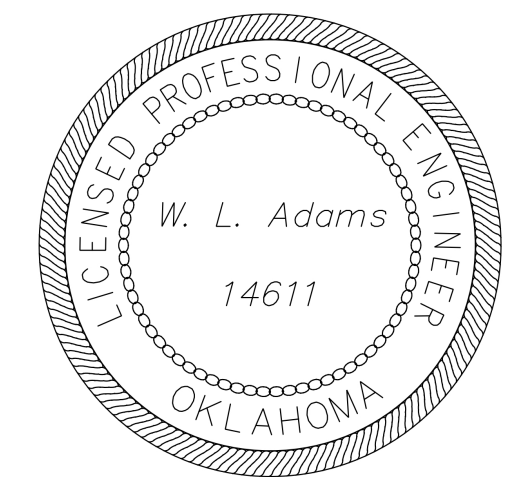

SHEET: 15

CHERRY PI ENGINEERING, LLC
 5105 W. 66TH ST. S. SUITE B
 TULSA, OK 74131
 918-205-0934

PROJECT: WIL ROGERS STAMPEDE ARENA VIP MEZZ. 2025
 DRAWING: MAIN COL'NS B02
 SHEET: 15
 DATE: 07/10/2025 BY: WIN ADAMS

MEZZANINE SUPPORT COLUMN PARTS DETAILS

PART # CTU01 HSS 5.563 X 0.375 X 27'-3 7/8" @20.8#/Ft 8 EA. REQ'D

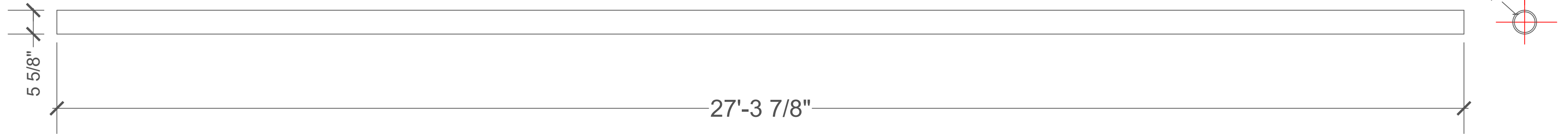

PART # CTU02 HSS 5.563 X 0.375 X 13'-3 7/8" @20.8#/Ft 20 EA. REQ'D

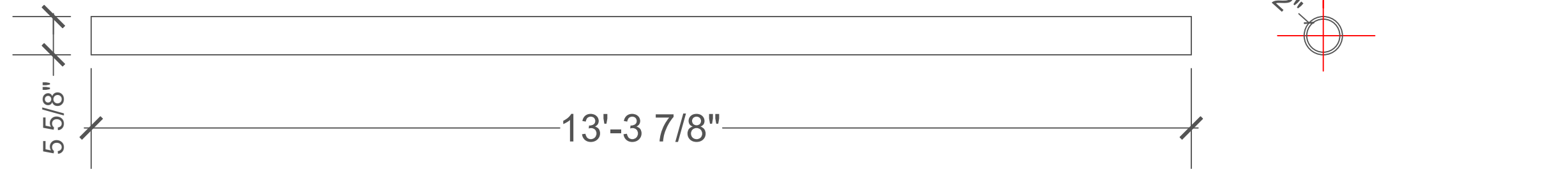

PART # CTU03 HSS 5.563 X 0.375 X 24'-3 1/2" @20.8#/Ft 8 EA. REQ'D

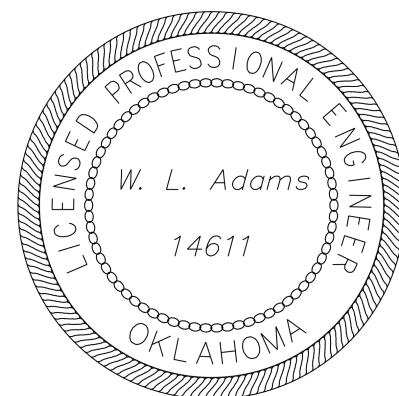
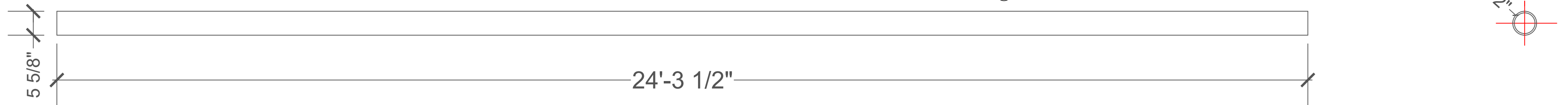

SHEET: 16

CHERRY PI ENGINEERING, LLC
5105 W. 66TH ST. S. SUITE B
TULSA, OK 74131
918-205-0934

PROJECT: WILL ROGERS STAMPEDE ARENA
VIP MEZZ. 2025
DRAWING: COLUMN PARTS ASSEMBLIES
SHEET: 16 DATE: 07/10/2025 BY: WIN ADAMS

COLUMN PARTS DETAILS

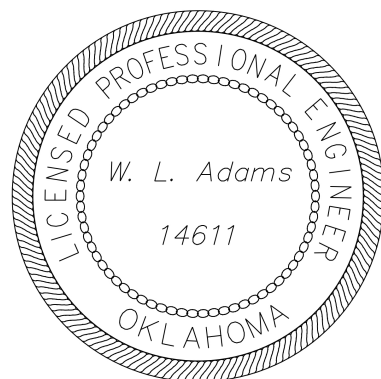
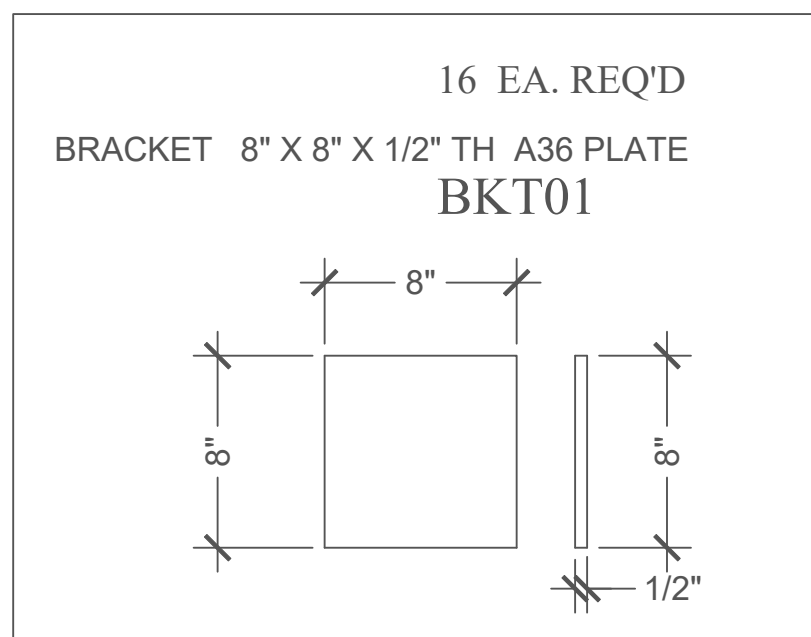
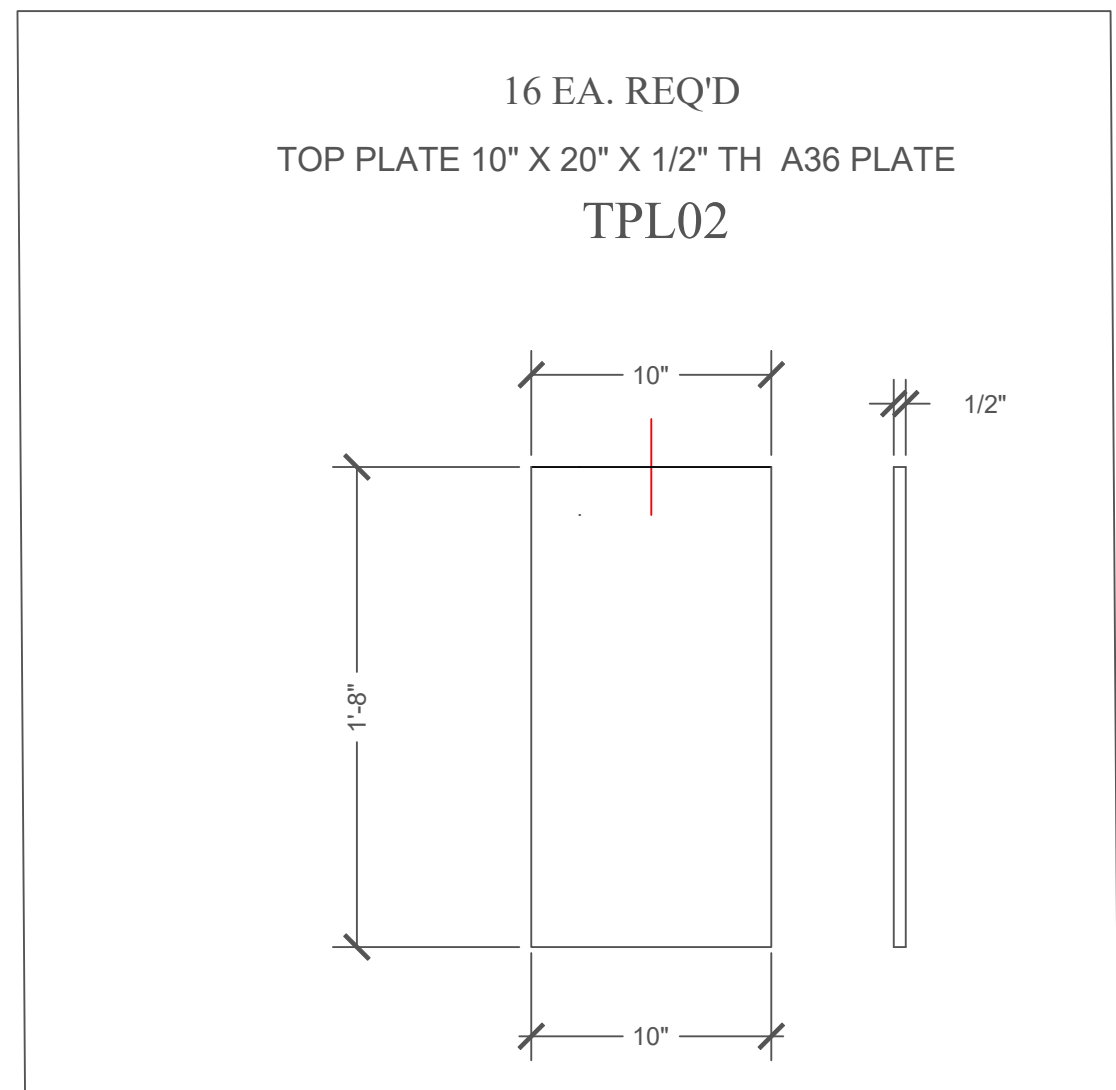
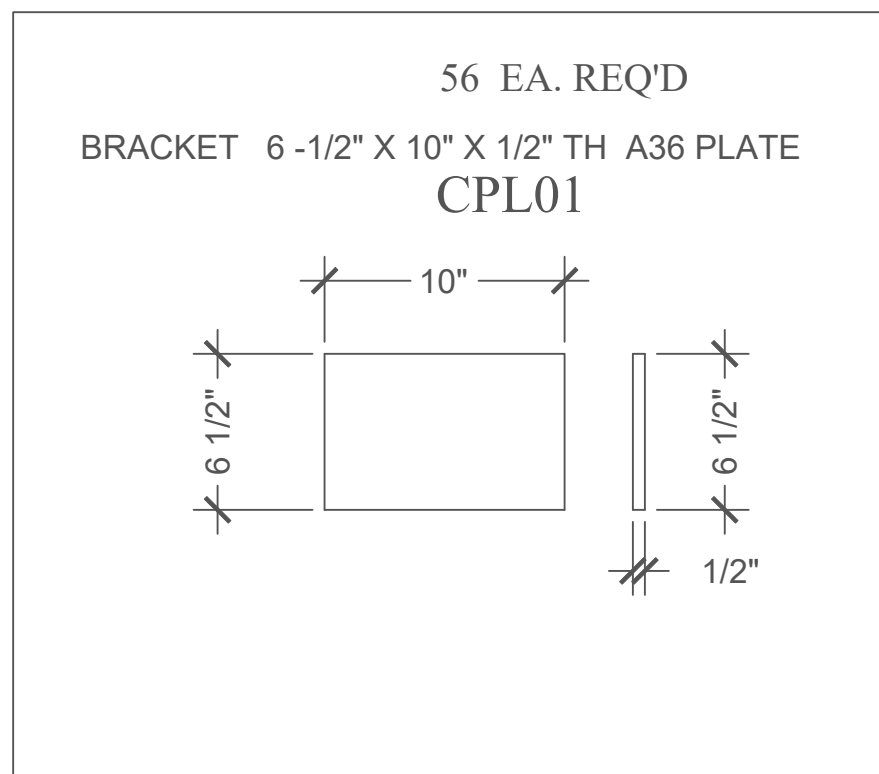
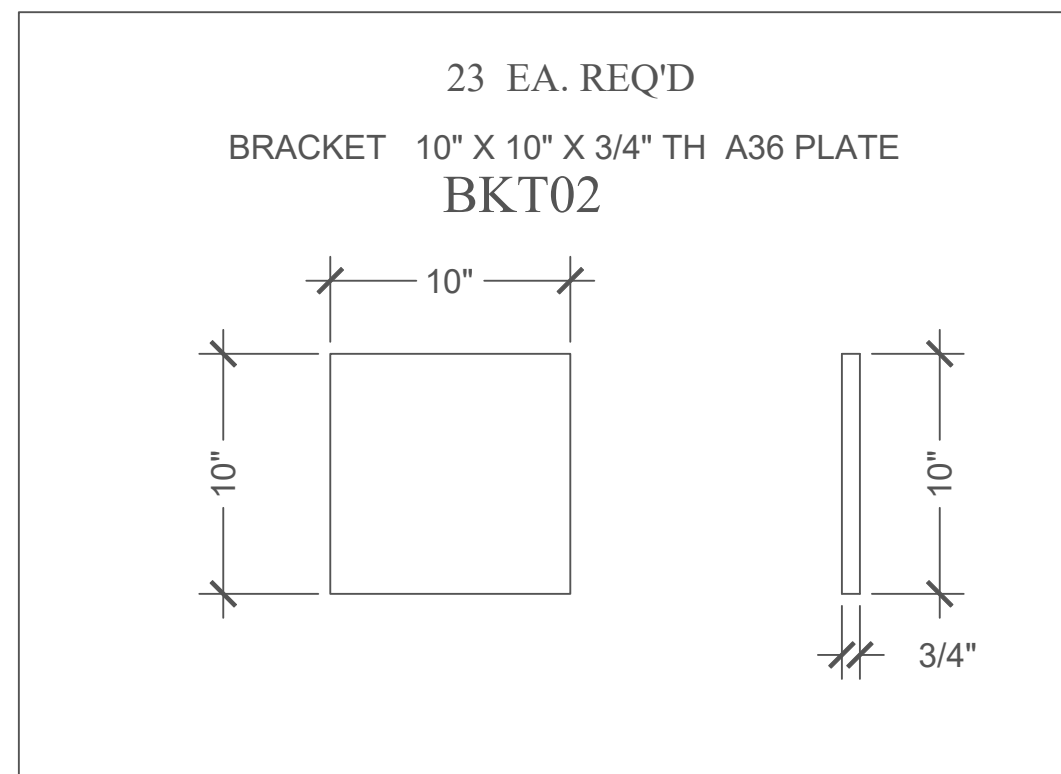
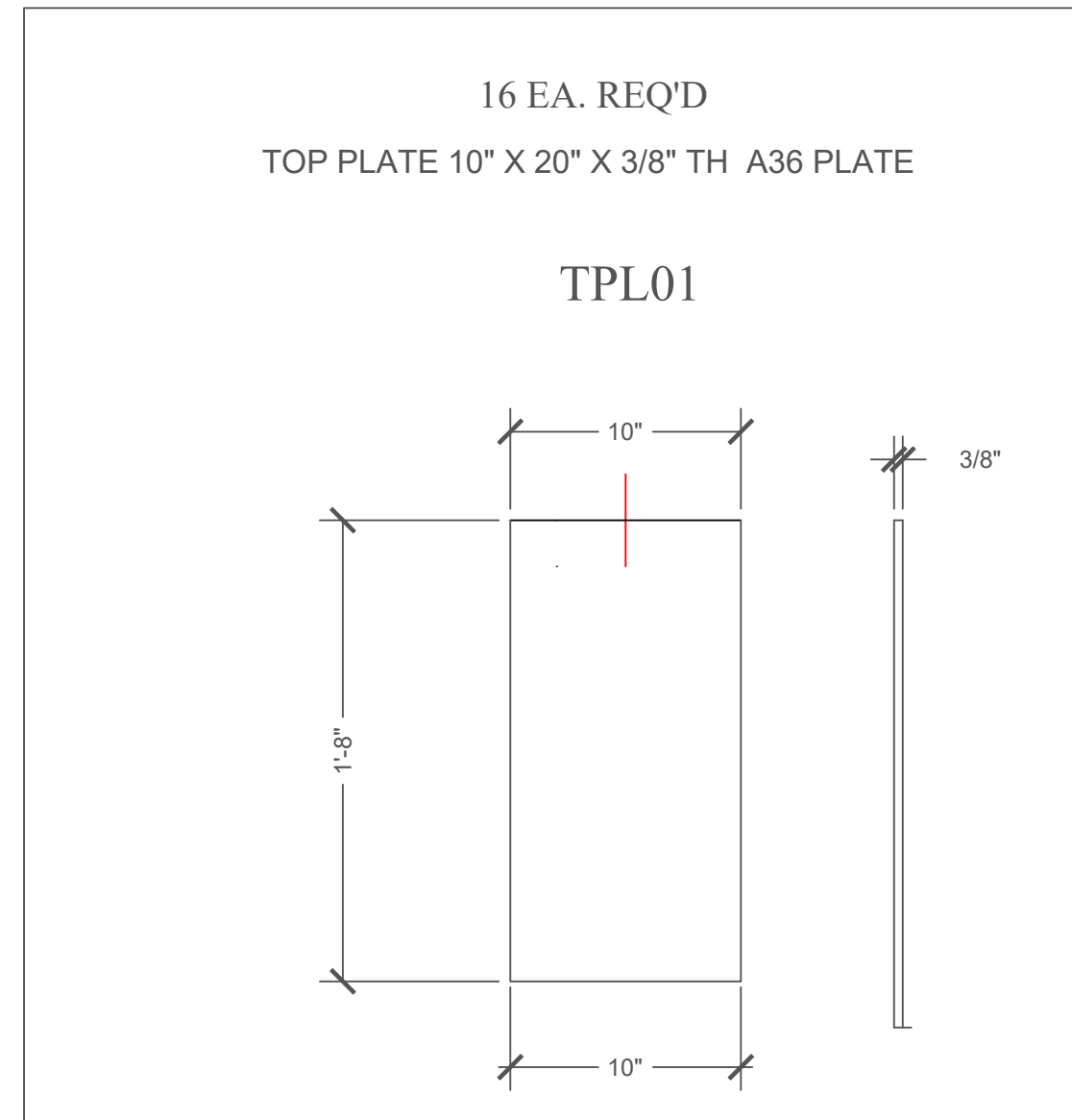
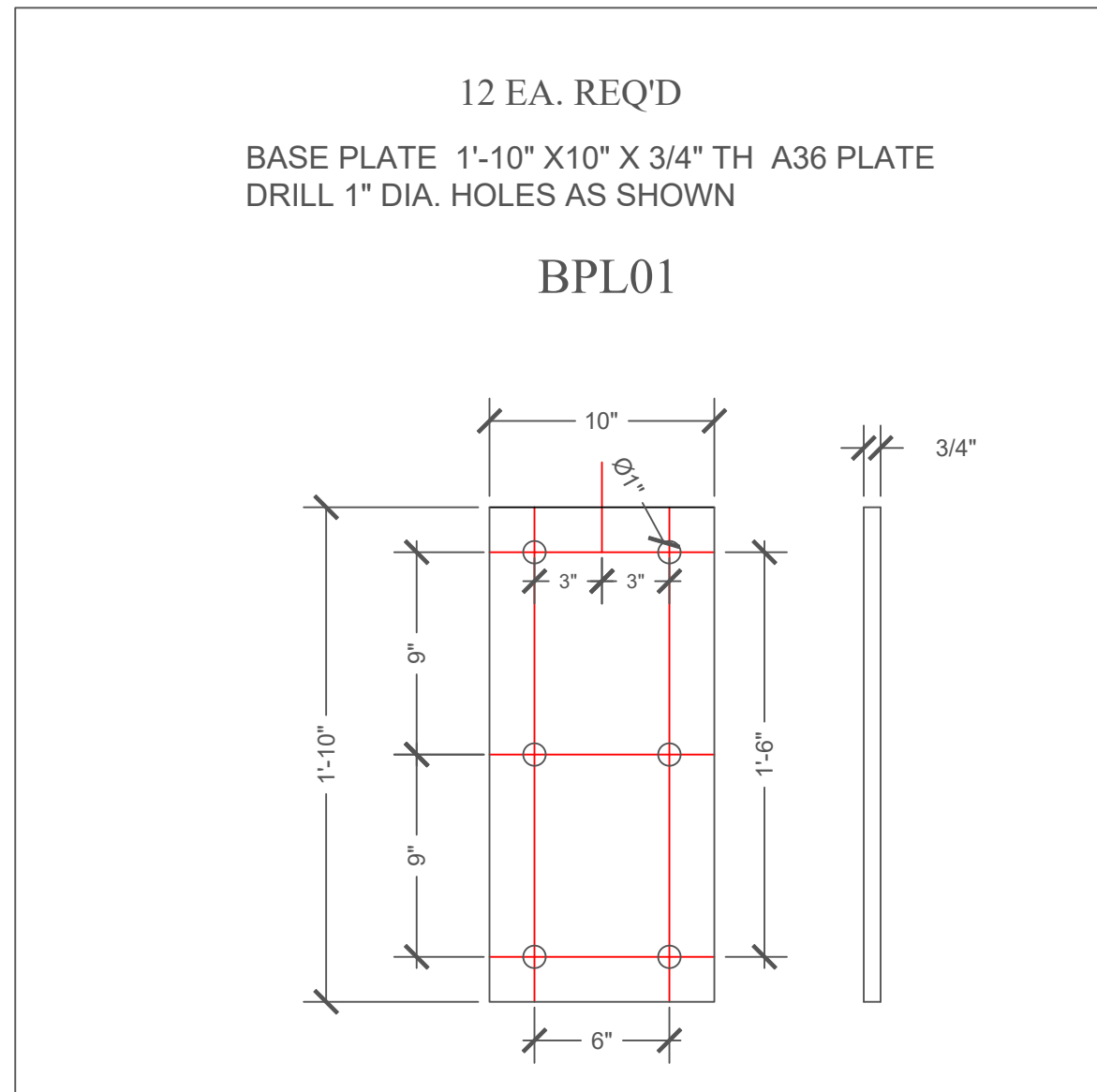
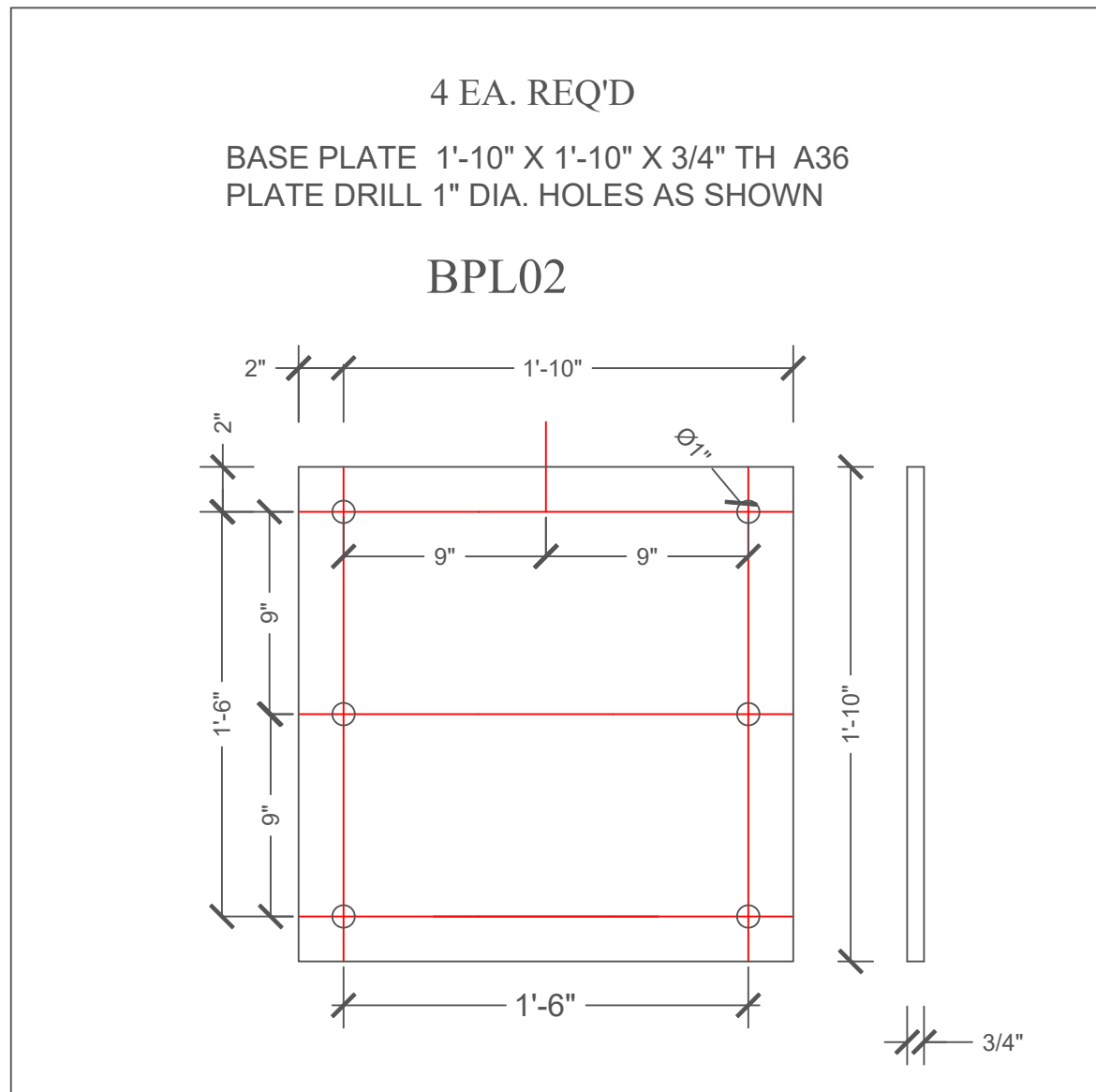

SHEET: 17

CHERRY PI ENGINEERING, LLC
 5105 W. 66TH ST. S. SUITE B
 TULSA, OK 74131
 918-205-0934

PROJECT: WIL ROGERS STAMPEDE ARENA VIP MEZZ. 2025
 DRAWING: COLUMN PARTS DETAILS
 SHEET: 17
 DATE: 07/10/2025 BY: WIN ADAMS

Will Rogers Stampede Arena VIP Mezzanine 2025

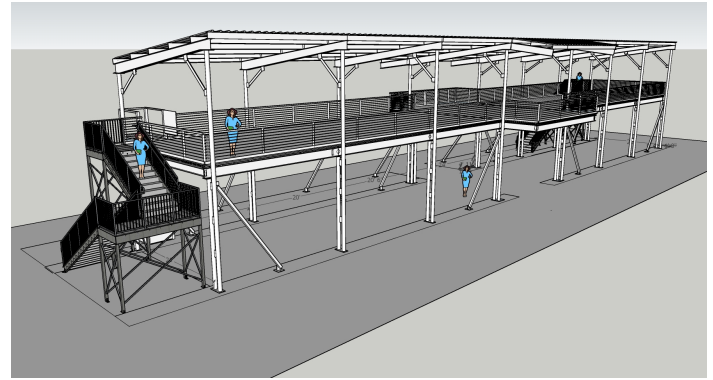
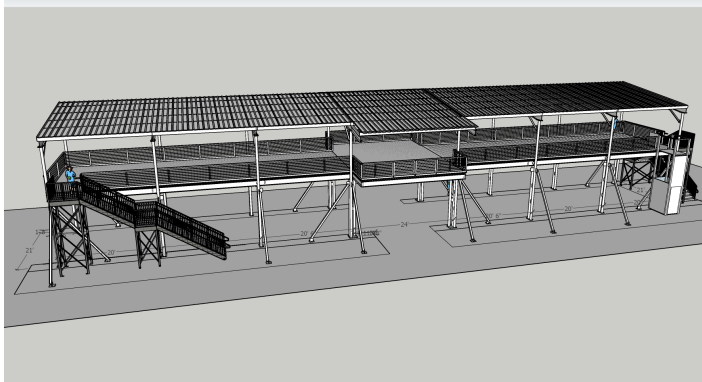

Engineering and Design
Cherry Pi Engineering LLC
5105 W. 66th St. S. Suite B
Tulsa, OK 74131
918-205-0934

Sean Wheeler, PE
Win Adams, PE

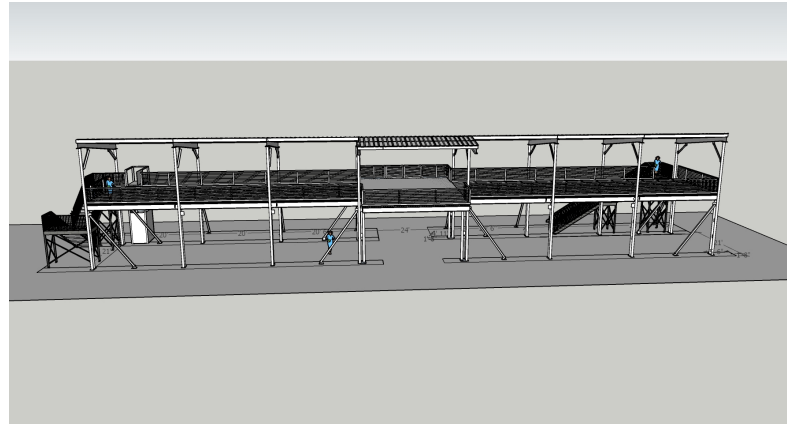
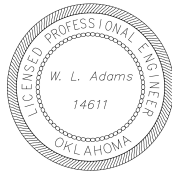

MEZZANINE RAFTER PLAN

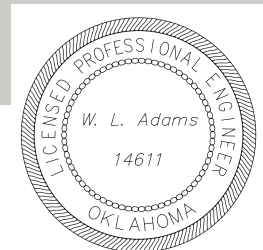
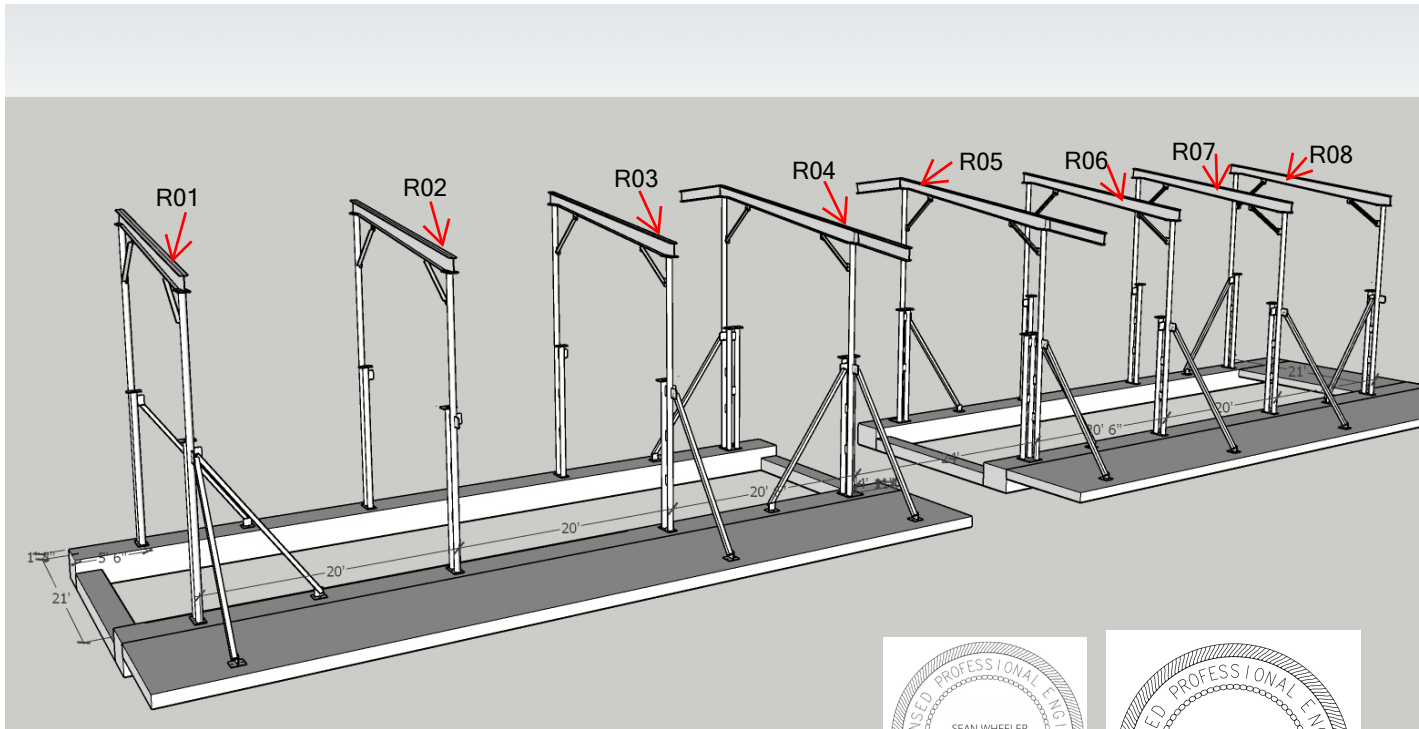

ROOF RAFTERS R01, R02,R03,R06,R07,R08

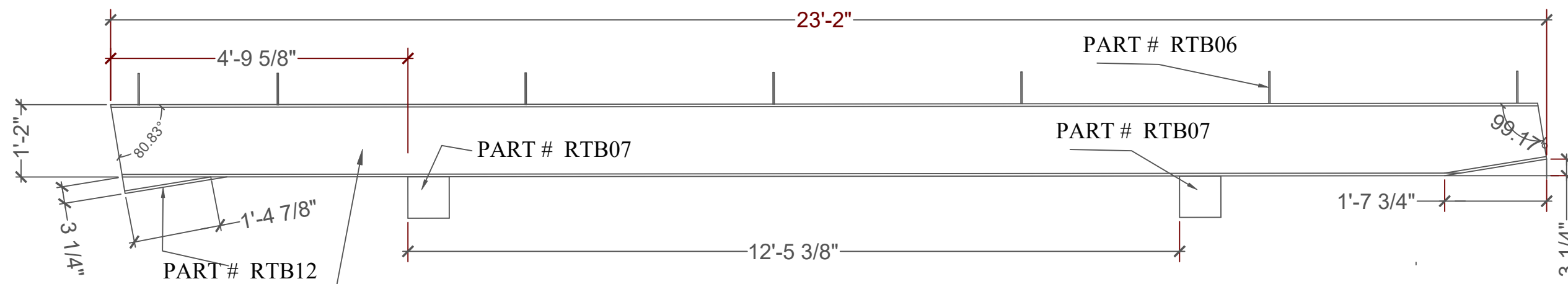

PART # RTB11 W14 X 34# X 23'-2"

- PARTS REQUIRED PER EACH RAFTER #
- PART # RTB11 W14 X 34# X 23'-2" 1 EA.
 - PART # RTB06 STD. METAL BLDG CLIP FOR PURLINS PRE DRILLED WELD TO TOP OF BEAM 12 EA.
 - PART # RTB07 8" X 8" X 1/2" PL A36 2 EA.
 - PART # RTB08 4" X 4" X 1/4" X 4'-10" ANGLE 1 EA.
 - PART # RTB09 4" X 4" X 1/4" X 5'-4" ANGLE 1 EA.
 - PART # RTB12 6 3/4" X 1'-5" X 1/2" PL A36 1 EA.

ROOF RAFTERS R01, R02,R03,R06,R07,R08

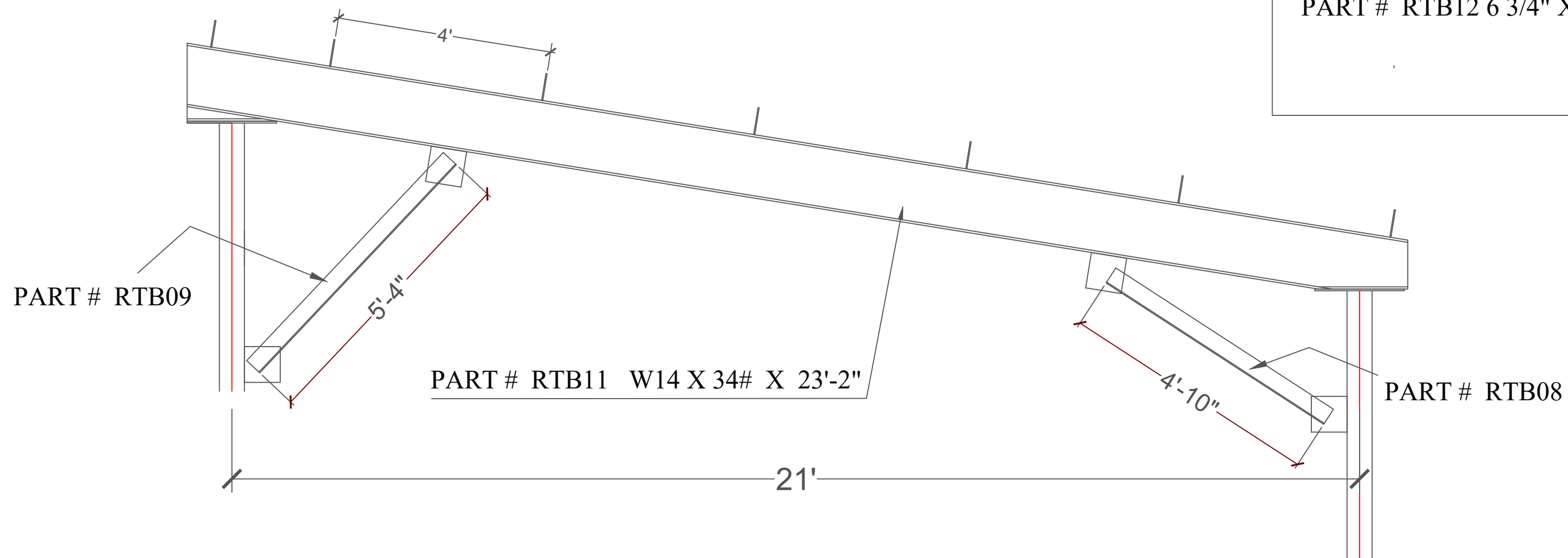

EAST

SHEET: 19

CHERRY PI ENGINEERING, LLC
5105 W. 66TH ST. S. SUITE B
TULSA, OK 74131
918-205-0934

PROJECT: WILL ROGERS STAMPEDE ARENA
VIP MEZZ. 2025
DRAWING: RAFTER ASSEMBLY
SHEET:19 DATE: 07/10/2025 BY: WIN ADAMS

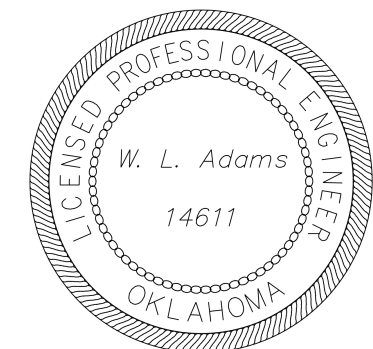

ROOF RAFTER R04, R05

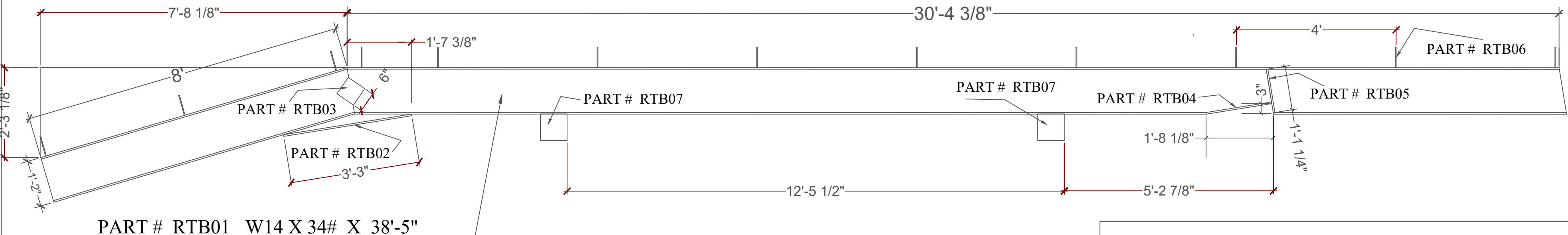

- PARTS REQUIRED PER EACH RAFTER #**
- PART # RTB01 W14 X 34# X 38'-5" 1 EA.
 - PART # RTB02 3'3" X 6-3/4" X 1/2" PL A36 1 EA.
 - PART # RTB03 6" X 6" X 1/4" PL A36 2 EA.
 - PART # RTB04 3 1/2" X 1'-8" X 1/4" PL A36 1 EA.
 - PART # RTB05 3 1/2" X 1'-1 1/4" X 1/4" PL A36 2 EA.
 - PART # RTB06 STD. METAL BLDG CLIP FOR PURLINS PRE DRILLED WELD TO TOP OF BEAM 12 EA.
 - PART # RTB07 8" X 8" X 1/2" PL A36 2 EA.
 - PART # RTB08 4" X 4" X 1/4" X 4'-10" ANGLE 1 EA.
 - PART # RTB09 4" X 4" X 1/4" X 5'-4" ANGLE 1 EA.

ROOF RAFTER R04 & R05

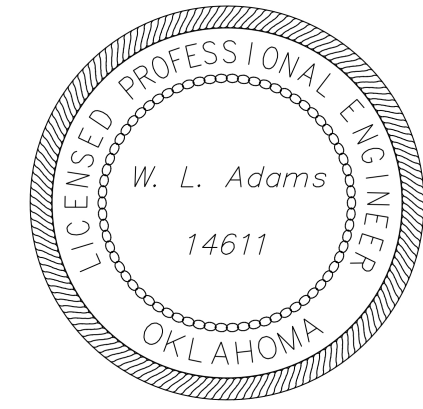
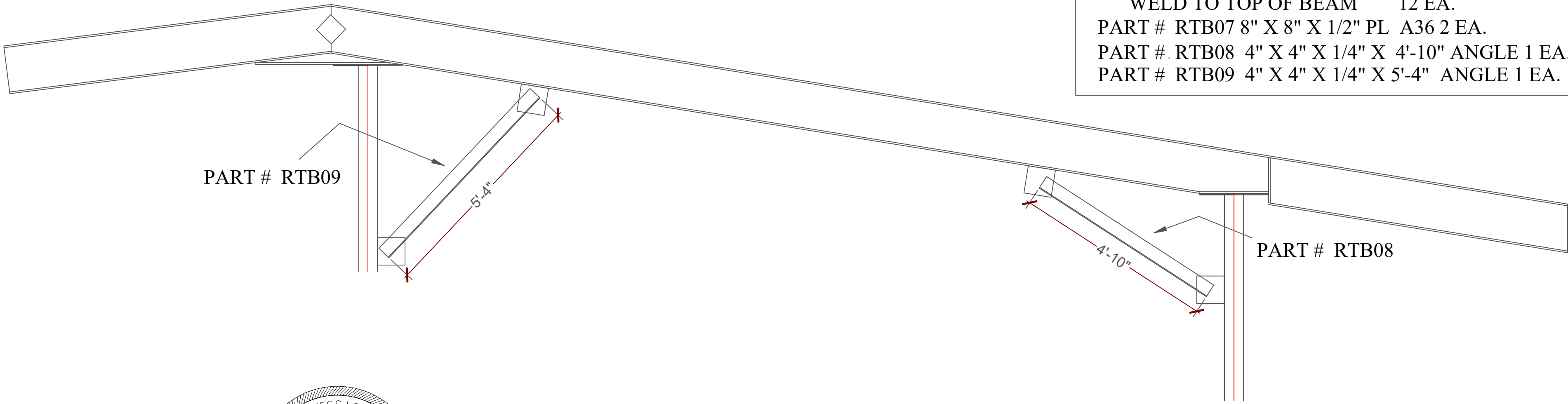

EAST →

SHEET: 20

CHERRY PI ENGINEERING, LLC
 5105 W. 66TH ST. S. SUITE B
 TULSA, OK 74131
 918-205-0934

PROJECT: WILL ROGERS STAMPEDE ARENA
 VIP MEZZ. 2025
 DRAWING: RAFTER ASSEMBLY R04 & R05
 SHEET:20 DATE: 07/10/2025 BY: WIN ADAMS

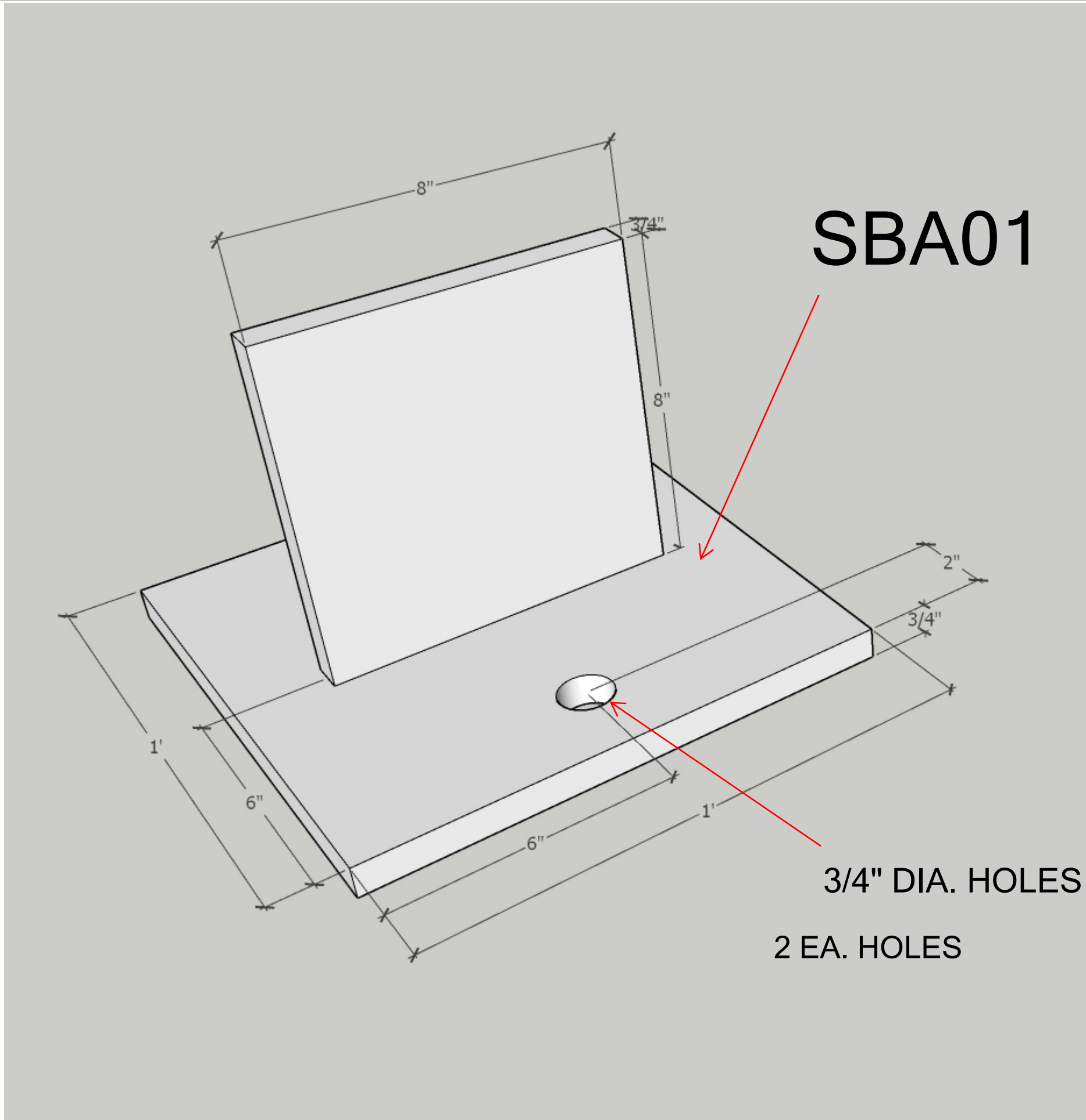

SWAY BRACE ANCHOR PLATE
 SBA01 12 EA. REQUIRED
 FABRICATE 2 EXTRAS FOR SPARES

ANCHOR PLATE TO CONCRETE USING
 HILTI ANCHORS

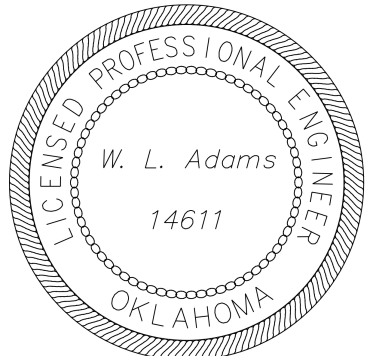

SWAY BRACE ANCHOR PLATE

SHEET: 21

CHERRY PI ENGINEERING, LLC
 5105 W. 66TH ST. S. SUITE B
 TULSA, OK 74131
 918-205-0934

PROJECT: WIL ROGERS STAMPEDE ARENA VIP MEZZ. 2025
 DRAWING: SWAY BRACE ANCHOR PLATE
 SHEET: 21
 DATE: 07/10/2025 BY: WIN ADAMS

PART # SWP01 SWAY BRACE

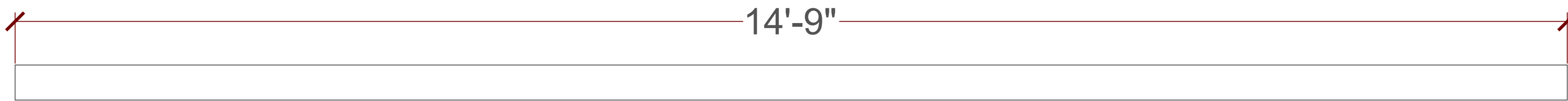

4" X 4" X 1/4" WALL SQ TUBING 12 EA. REQUIRED

FIELD WELD TO SWAY BRACE ANCHOR PLATES

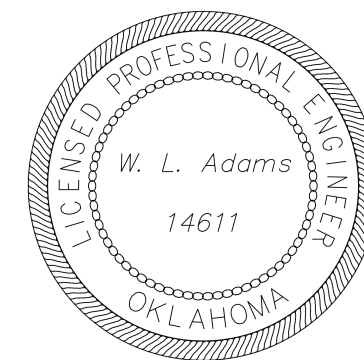

SHEET: 22

CHERRY PI ENGINEERING, LLC
5105 W. 66TH ST. S. SUITE B
TULSA, OK 74131
918-205-0934

PROJECT: WILL ROGERS STAMPEDE ARENA
VIP MEZZ. 2025
DRAWING: SWAY BRACE
SHEET: 22 DATE: 07/10/2025 BY: WIN ADAMS

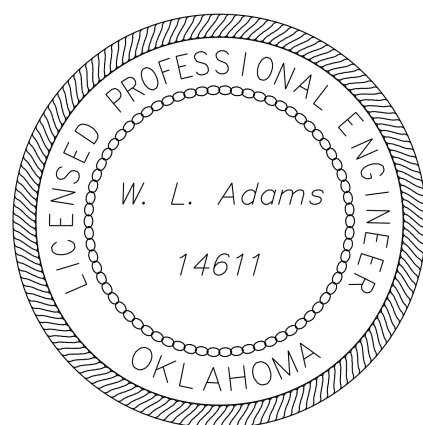
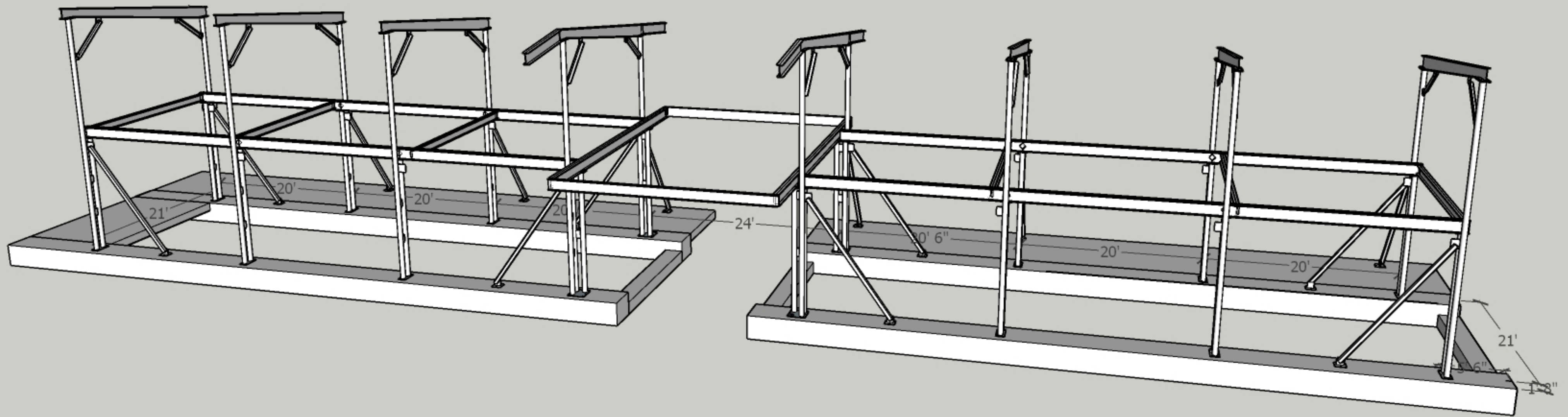

SHEET: 23

CHERRY PI ENGINEERING, LLC
 5105 W. 66TH ST. S. SUITE B
 TULSA, OK 74131
 918-205-0934

PROJECT: WIL ROGERS STAMPEDE ARENA VIP MEZZ. 2025
 DRAWING: FLOOR SUPPORT BEAM LOCATIONS
 SHEET: 23
 DATE: 07/10/2025 BY: WIN ADAMS

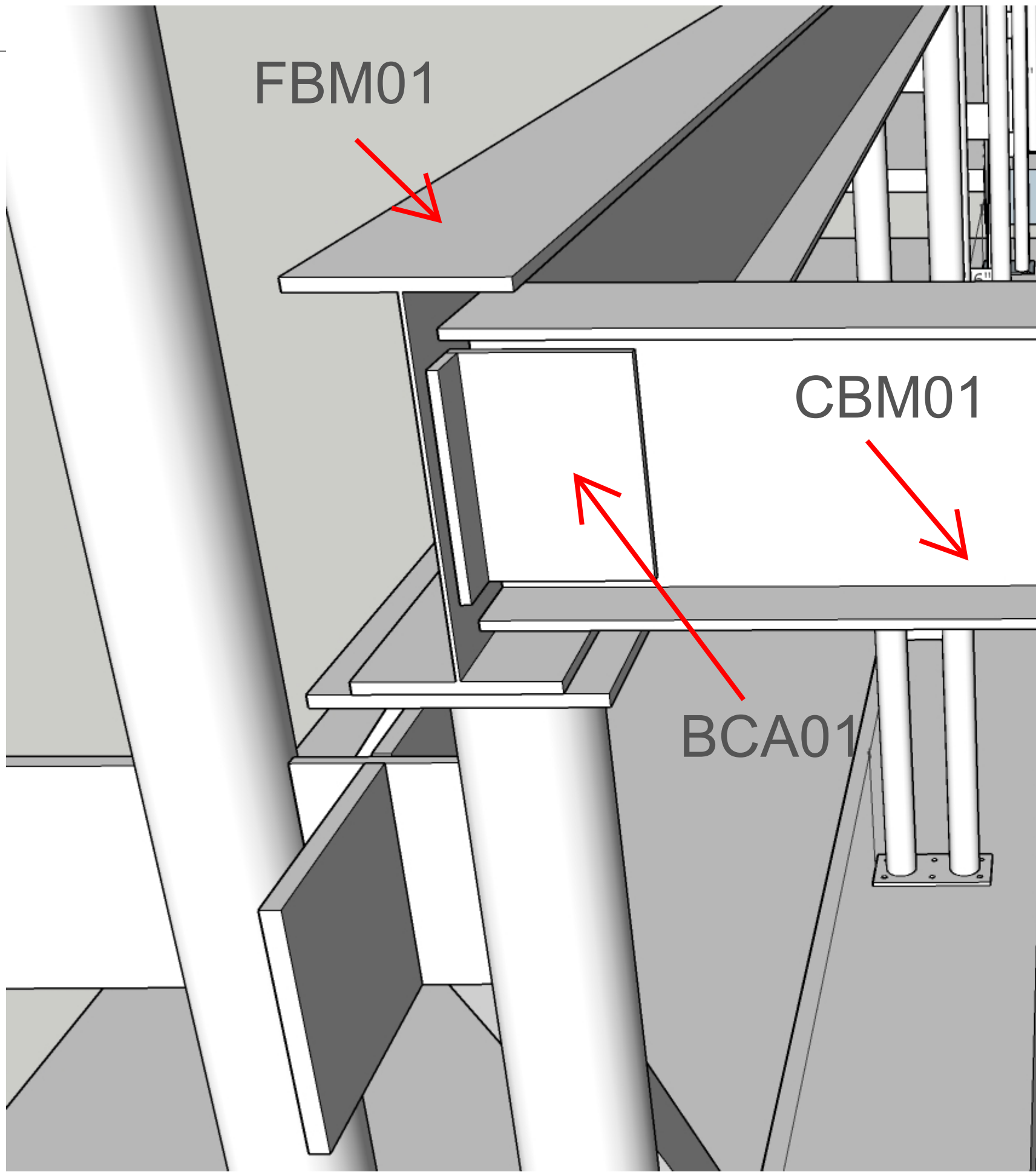

FLOOR BEAMS ARE SPLICED TOGETHER USING SPLICE PATES. ONE ON EACH SIDE OF BEAM SPLICE.

PLATES SHALL BE 6" X 6" X 1/4" A36 PLATE. FBS01 16 EACH REQUIRED

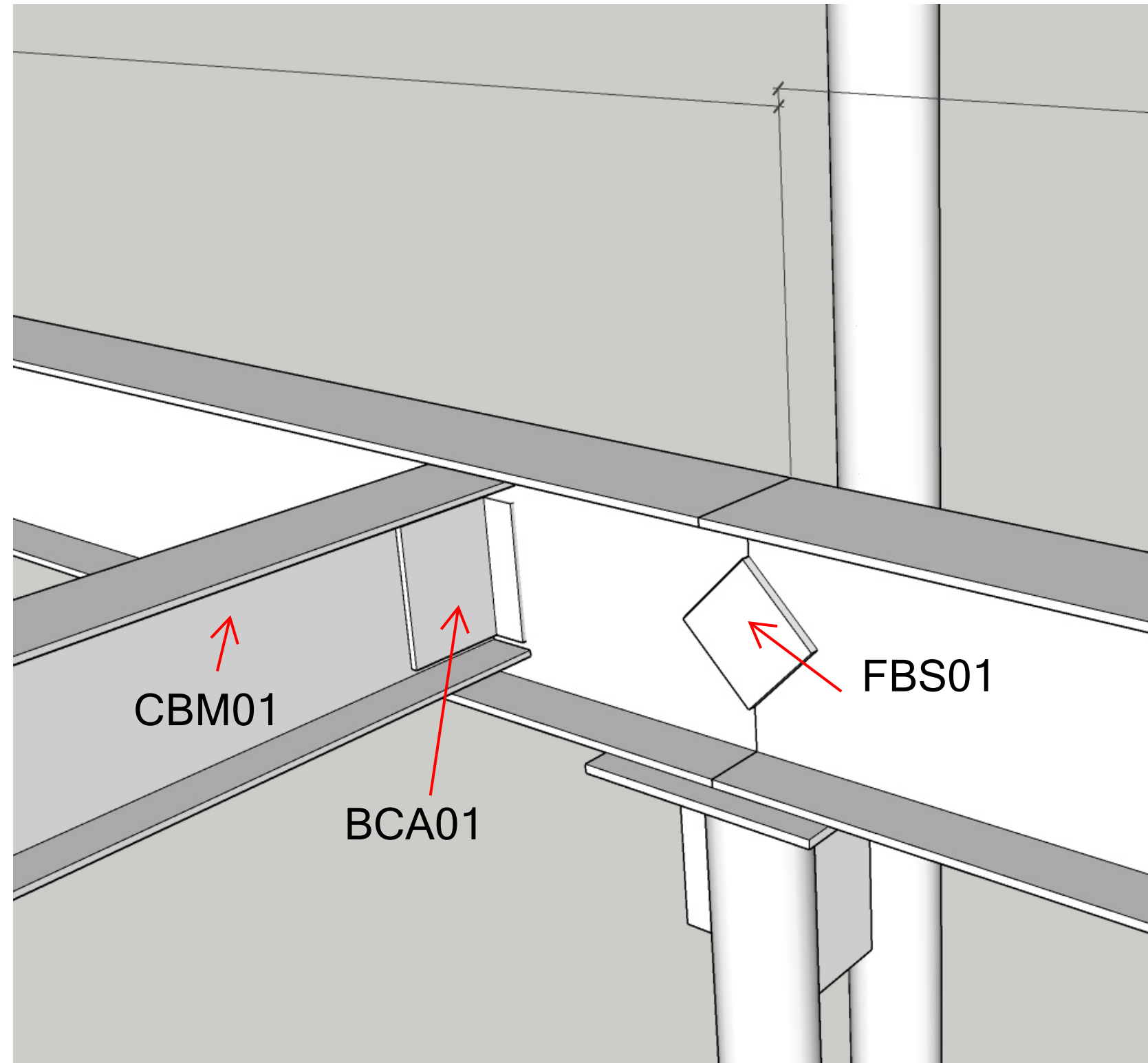

ATTACH COMPONENTS FLOOR BEAM (FBM) TO FLOOR CROSS BEAMS (CBM) USING BEAM CONNECTING ANGLES (BCA). FLOOR BEAM ATTACHES TO THE COLUMN PLATE BY WELDING USE APPROVED WELDING PROCEDURES.

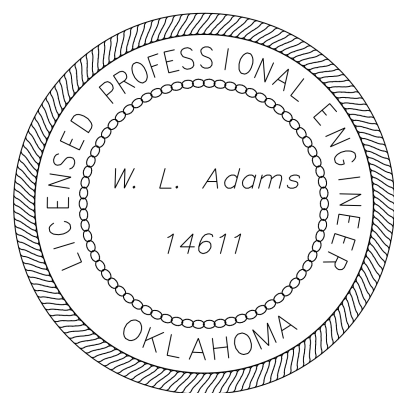

SHEET: 24

CHERRY PI ENGINEERING, LLC
 5105 W. 66TH ST. S. SUITE B
 TULSA, OK 74131
 918-205-0934

PROJECT: WIL ROGERS STAMPEDE ARENA VIP MEZZ. 2025
 DRAWING: FLOOR SUPPORT BEAM LOCATIONS
 SHEET: 24
 DATE: 07/10/2025 BY: WIN ADAMS

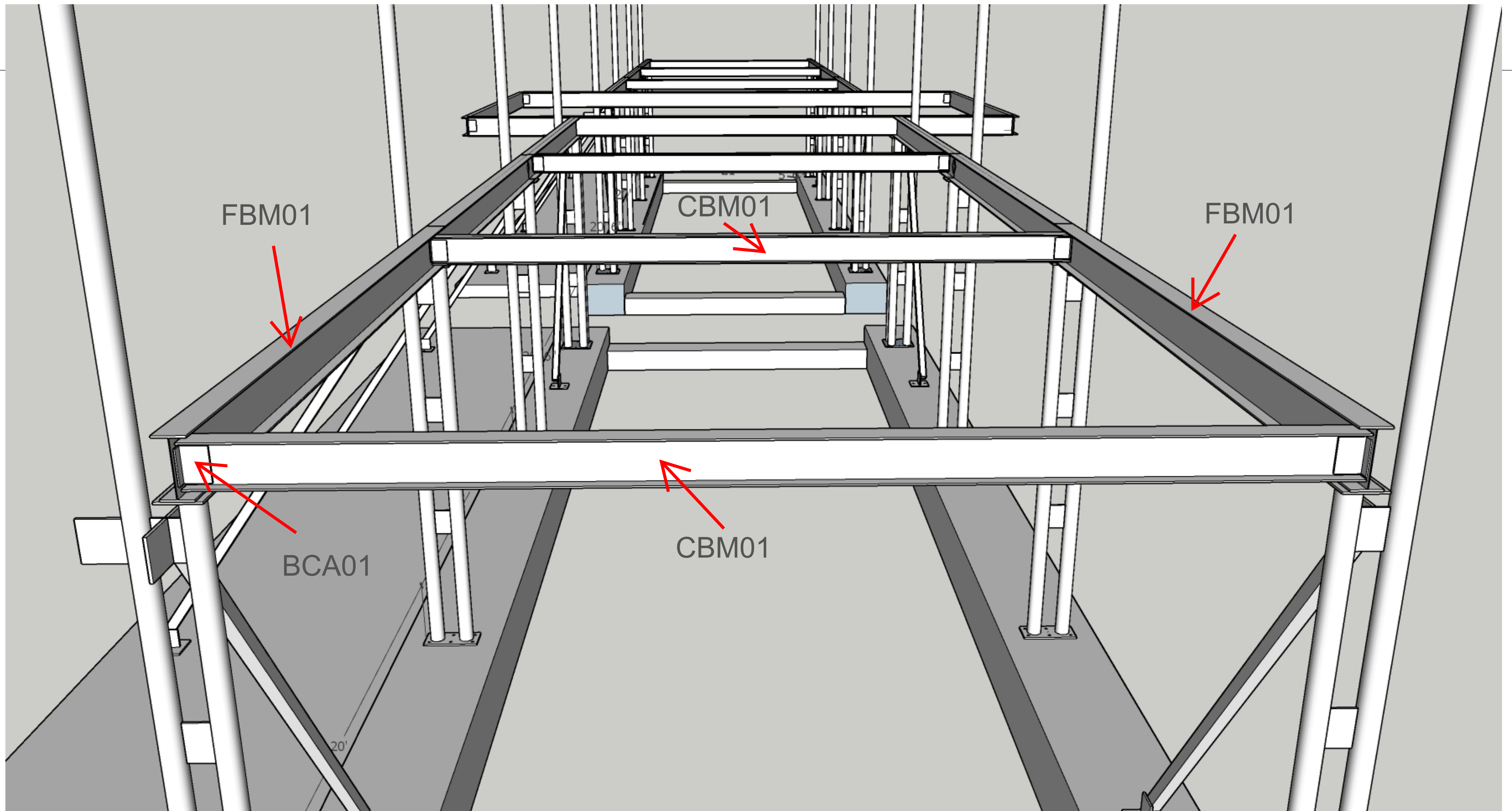

ATTACH MAIN FLOOR BEAMS (FTBM) TO CROSS BEAMS (CBM) USING BEAM CONNECTING ANGLE (BCM).
 USE APPROVED WELDING PROCEDURES. WELD BEAMS AND ANGLES TO COLUMN SUPPORT PLATES.

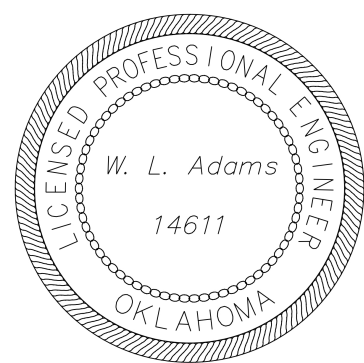

SHEET: 25

CHERRY PI ENGINEERING, LLC
 5105 W. 66TH ST. S. SUITE B
 TULSA, OK 74131
 918-205-0934

PROJECT: WIL ROGERS STAMPEDE ARENA VIP MEZZ. 2025
 DRAWING: FLOOR SUPPORT BEAM LOCATIONS
 SHEET: 25
 DATE: 07/16/2025 BY: WIN ADAMS

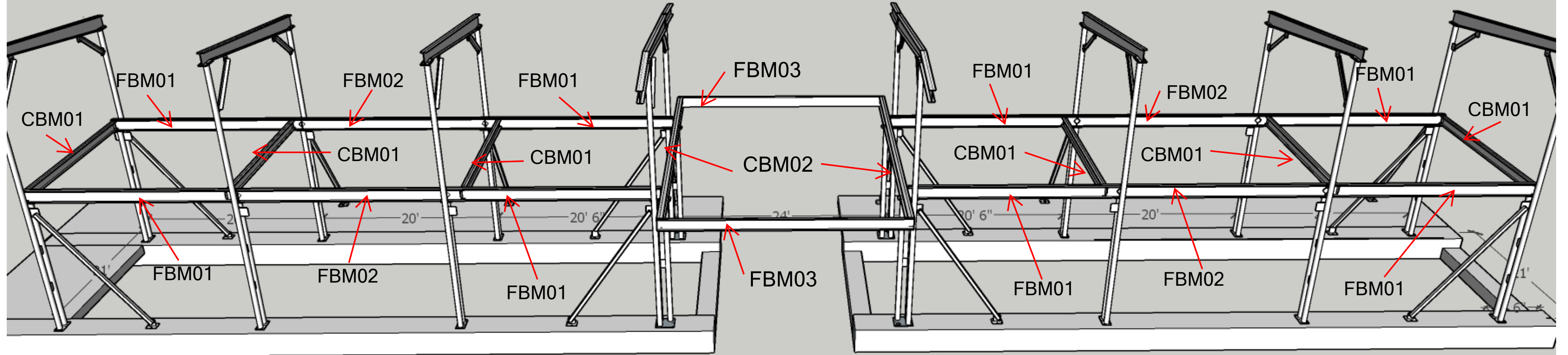

FBM01 - W14 X 53# X 20'-7" LG 8 EA. REQUIRED
 FBM02 - W14 X 53# X 20'-0" LG 4 EA. REQUIRED
 FBM03 - C12 X 20.7# X 23'-7" LG 2 EA. REQUIRED

FLOOR BEAM LOCATIONS.

CBM01 - W10 X 26# X 19'-11" LG 6 EA. REQUIRED
 CBM02 - W14 X 53# X 34'-0" 2 EA. REQ'D

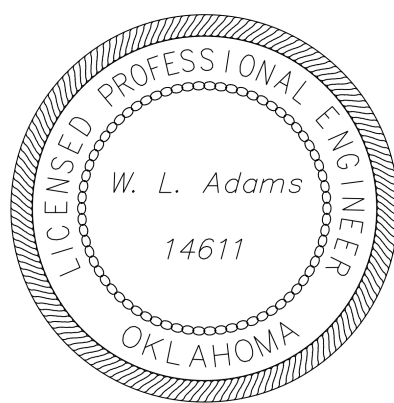

SHEET: 26

CHERRY PI ENGINEERING, LLC
 5105 W. 66TH ST. S. SUITE B
 TULSA, OK 74131
 918-205-0934

PROJECT: WIL ROGERS STAMPEDE ARENA VIP MEZZ. 2025
 DRAWING: FLOOR SUPPORT BEAM LOCATIONS
 SHEET: 26
 DATE: 07/10/2025 BY: WIN ADAMS

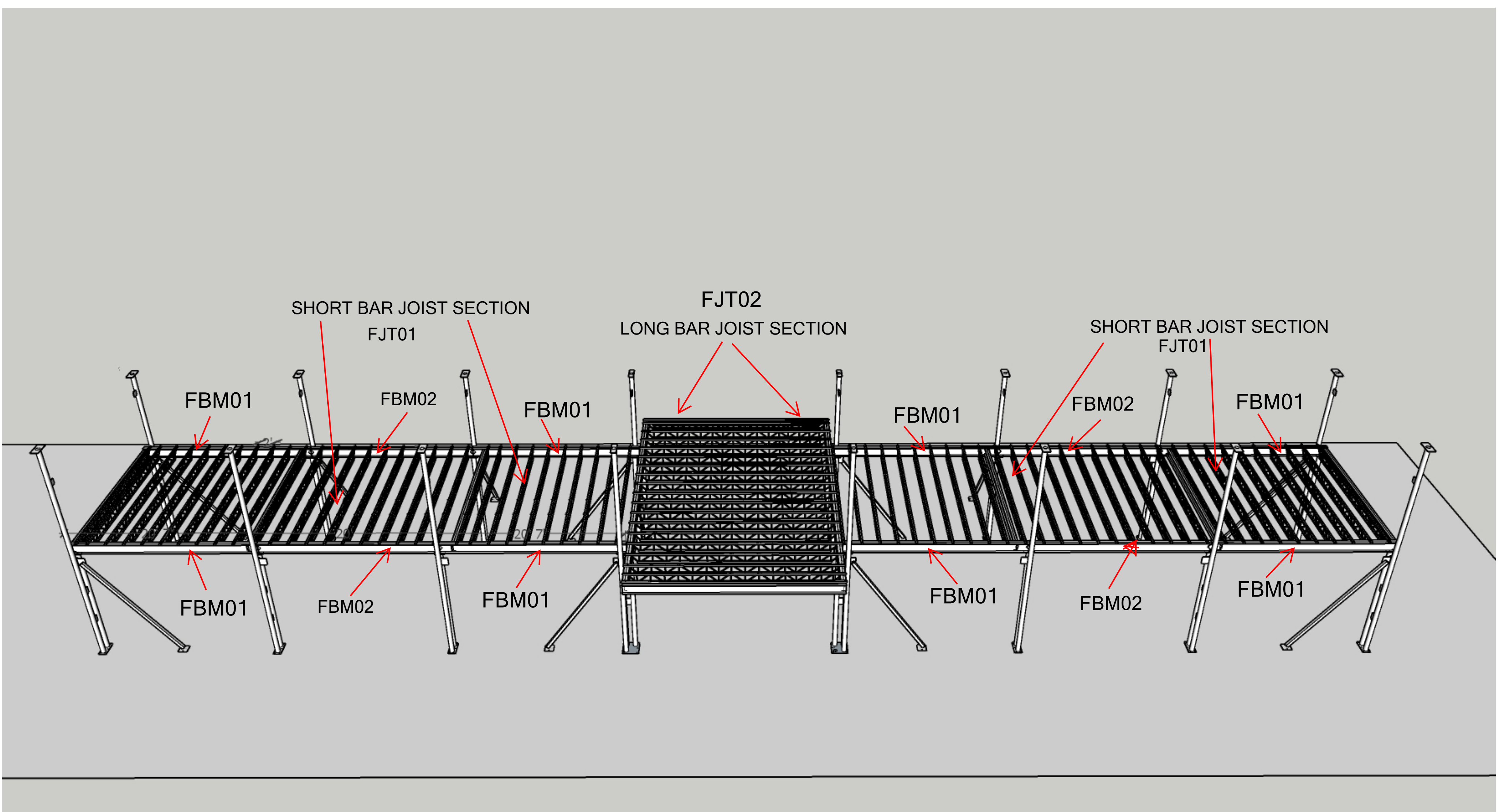

SHORT BAR JOIST SECTION
FJT01

FBM01 FBM02 FBM01

LONG BAR JOIST SECTION
FJT02

FBM01 FBM02 FBM01

SHORT BAR JOIST SECTION
FJT01

FBM01 FBM02 FBM01

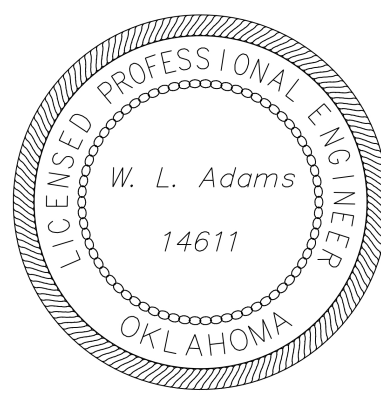

NORTH
←

SHEET: 27

CHERRY PI ENGINEERING, LLC
5105 W. 66TH ST. S. SUITE B
TULSA, OK 74131
918-205-0934

PROJECT: WILL ROGERS STAMPEDE ARENA
VIP MEZZ. 2025
DRAWING: BARJOIST LOCATION
SHEET: 27 DATE: 07/10/2025 BY: WIN ADAMS

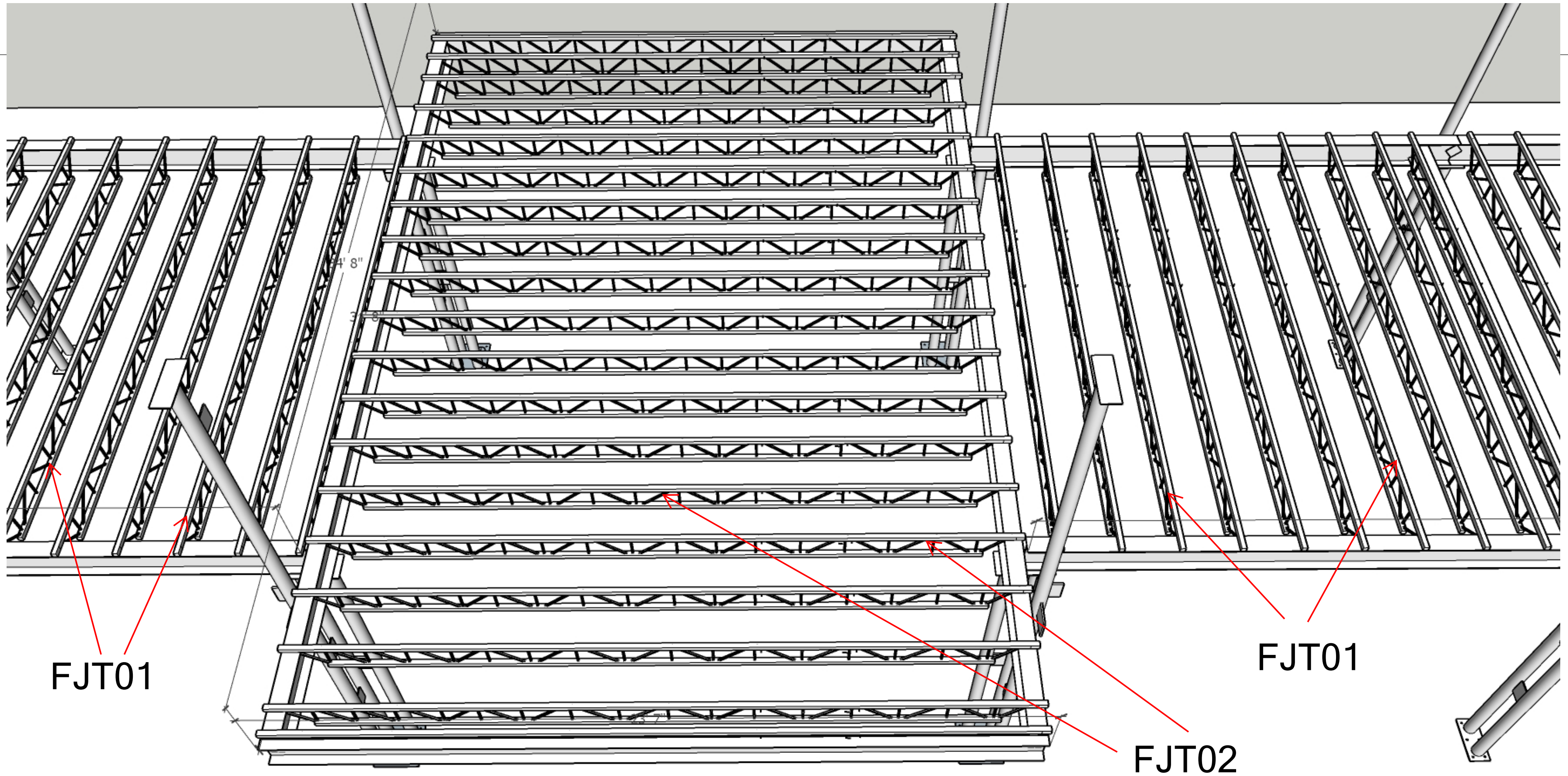

BAR JOISTS SHALL BE NUCOR/VULCRAFT OR EQUIVALENT DESIGNED TO SUPPORT FLOOR DECKING WITH 4 INCH THICK LITE WEIGHT CONCRETE CAST IN PLACE UPON THE METAL DECKING.

FJT01- SHORT SPAN BAR JOISTS SHALL BE 18K357/250 MINIMUM WITH A TOTAL LENGTH OF 20'-7" WITH 9" LEGS TO SET FLAT ON SUPPORT BEAMS. THEY SHOULD BE MANUFACTURED TO SET DOWN BETWEEN CLEARANCE OF 19'-2".

FJT02 - LONG SPAN BARJOIST SHALL BE 18K357/250 MINIMUM WITH A TOTAL LENGTH OF 23'-7" WITH 9" LEGS TO SET FLAT ON SUPPORT BEAMS. THEY SHOULD BE MANUFACTURED TO SET DOWN BETWEEN CLEARANCE OF 21'-9".

*BARJOISTS SHOWN ABOVE ARE NOT EXACT TO SIZE OR SCALE. THEY ARE APPROXIMATE.

BAR JOIST BRIDGING SHALL BE INSTALLED PER MANUFACTURERS SPECIFICATIONS.

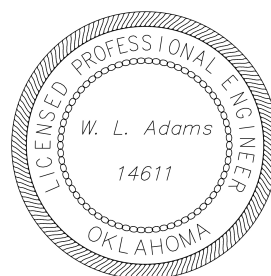

SHEET: 28

NORTH



CHERRY PI ENGINEERING, LLC
5105 W. 66TH ST. S. SUITE B
TULSA, OK 74131
918-205-0934

PROJECT: WILL ROGERS STAMPEDE ARENA
VIP MEZZ. 2025
DRAWING: BARJOIST LOCATION
SHEET: 28 DATE: 07/10/2025 BY: WIN ADAMS

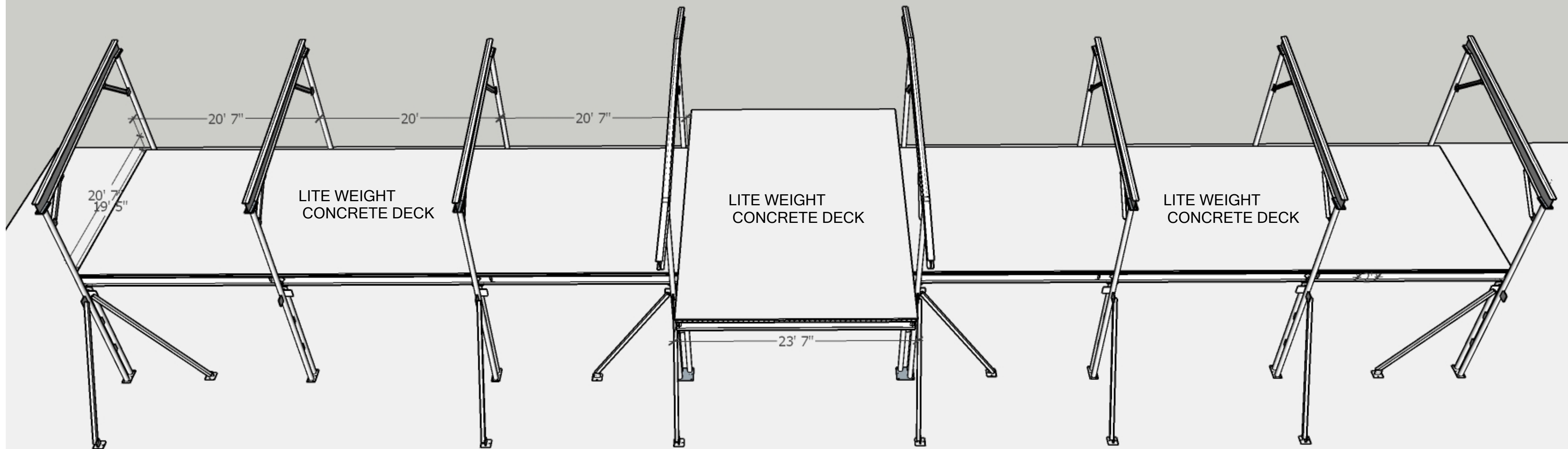

INSTALL APPROVED METAL RIBBED DECKING OVER BAR JOISTS. DECKING SHALL MEET BAR JOIST MANUFACTURERS RECOMMENDATIONS. LITE WEIGHT CONCRETE 4" NOM. THICKNESS SHALL BE CAST IN PLACE UPON THE METAL DECKING. CONTROL JOINTS SHALL BE INSTALLED PER MANUFACTURERS SPECIFICATIONS. CONCRETE DECK SHALL BE TRUE AND LEVEL TO STANDARD PRACTICES.

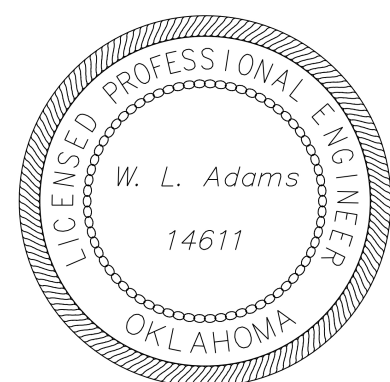

SHEET: 29

NORTH



CHERRY PI ENGINEERING, LLC
 5105 W. 66TH ST. S. SUITE B
 TULSA, OK 74131
 918-205-0934

PROJECT: WILL ROGERS STAMPEDE ARENA
 VIP MEZZ. 2025
 DRAWING: DECK AND CONCRETE DECK
 SHEET: 92 DATE: 07/10/2025 BY: WIN ADAMS

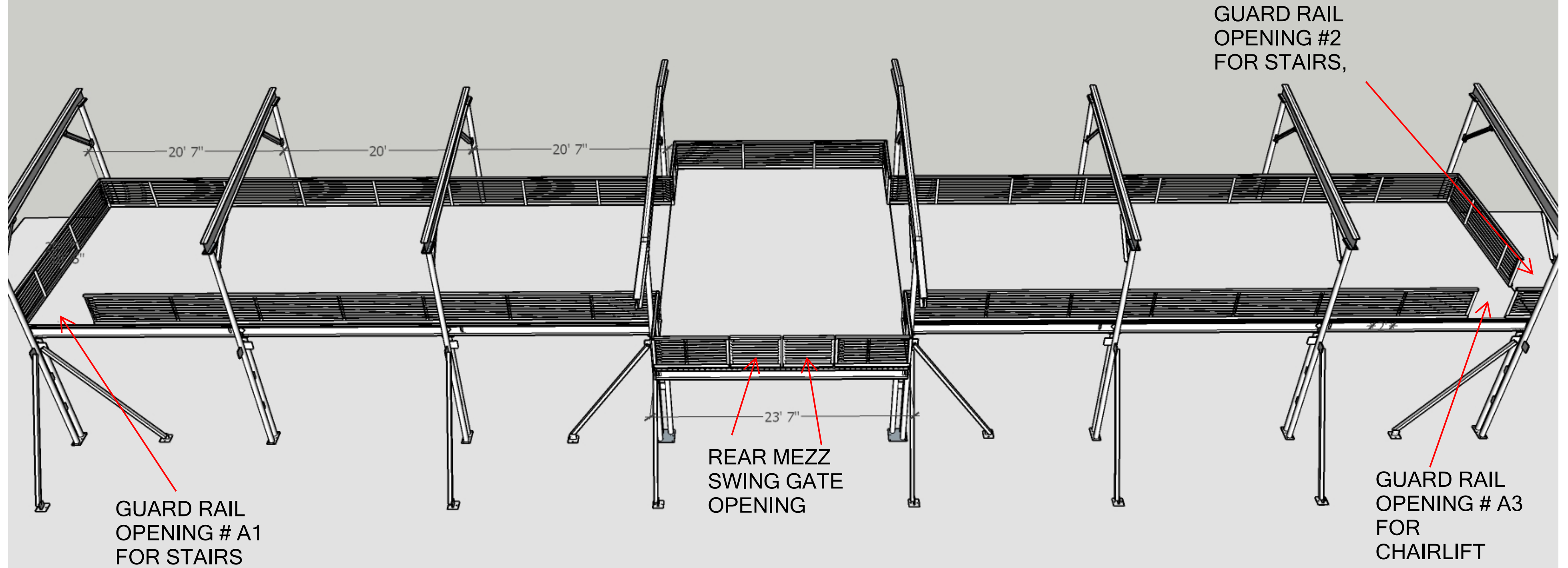

INSTALL PERIMETER HAND AND GUARD RAIL PER DRAWINGS AND TO MEET APPLICABLE BUILDING CODES. THIS DRAWING IS TO BE USED TO LOCATE THE OPENINGS FOR TWO SETS OF STAIRS AND AN CHAIR LIFT. THERE SHALL BE A DOUBLE GATE OPENING AS SHOWN. THERE SHALL BE TENSION SPRINGS ATTACHED TO THE GUARD RAIL CABLES. GUARD RAIL SHALL BE PAINTED WITH OWNER SELECTED ENAMEL COLOR PRIOR TO INSTALLING THE TENSION CABLES. THE GUARD RAIL SHALL HAVE A BASE PERIMETER STEEL BASE ANGLE TO ACT AS A TOE BOARD. THIS ANGLE SHALL BE 4" X 3" X 3/8"

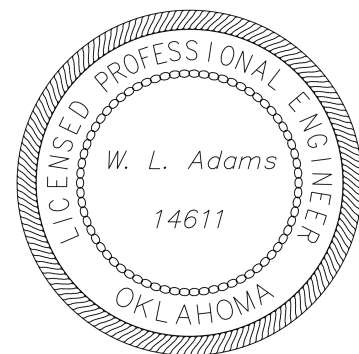

SHEET: 30

NORTH
→

CHERRY PI ENGINEERING, LLC
5105 W. 66TH ST. S. SUITE B
TULSA, OK 74131
918-205-0934

PROJECT: WILL ROGERS STAMPEDE ARENA
VIP MEZZ. 2025
DRAWING: GUARD RAIL
SHEET: 30 DATE: 07/10/2025 BY: WIN ADAMS

PERIMETER GUARD/HAND RAIL CONSTRUCTION

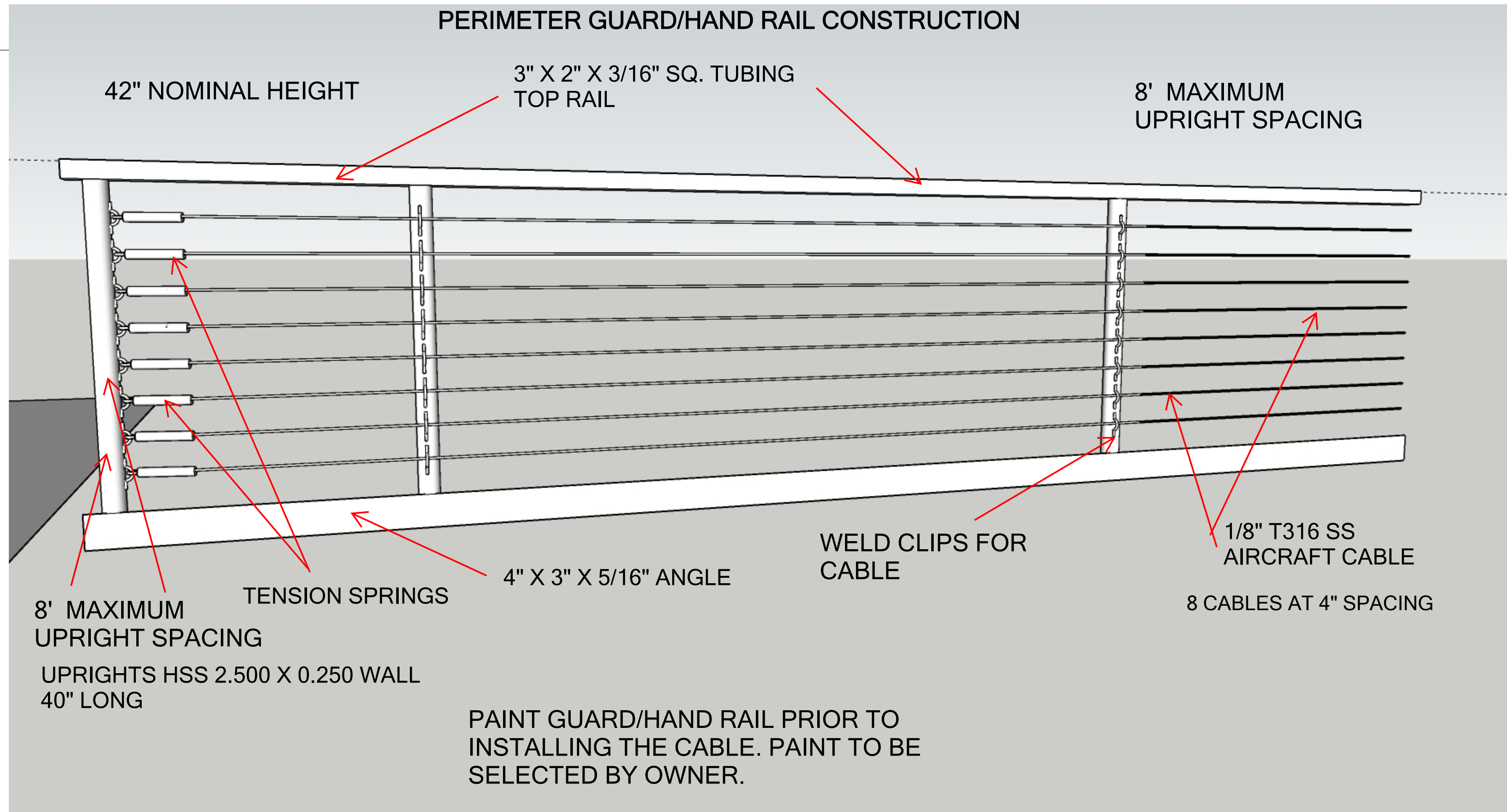

INSTALL PERIMETER HAND AND GUARD RAIL PER DRAWINGS AND TO MEET APPLICABLE BUILDING CODES. THIS DRAWING IS TO BE USED TO LOCATE THE OPENINGS FOR TWO SETS OF STAIRS AND AN CHAIR LIFT. THERE SHALL BE TENSION SPRINGS ATTACHED TO THE GUARD RAIL CABLES. GUARD RAIL SHALL BE PAINTED WITH OWNER SELECTED ENAMEL COLOR PRIOR TO INSTALLING THE TENSION CABLES.

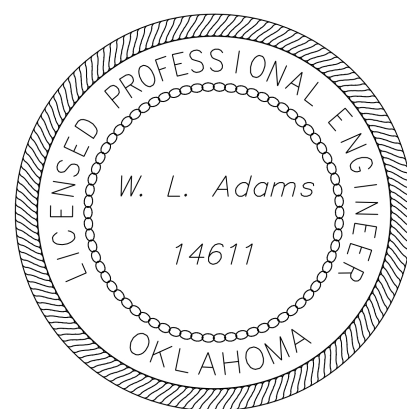

SHEET: 31



CHERRY PI ENGINEERING, LLC
 5105 W. 66TH ST. S. SUITE B
 TULSA, OK 74131
 918-205-0934

PROJECT: WILL ROGERS STAMPEDE ARENA
 VIP MEZZ. 2025
 DRAWING: GUARD RAIL
 SHEET: 31 DATE: 07/10/2025 BY: WIN ADAMS

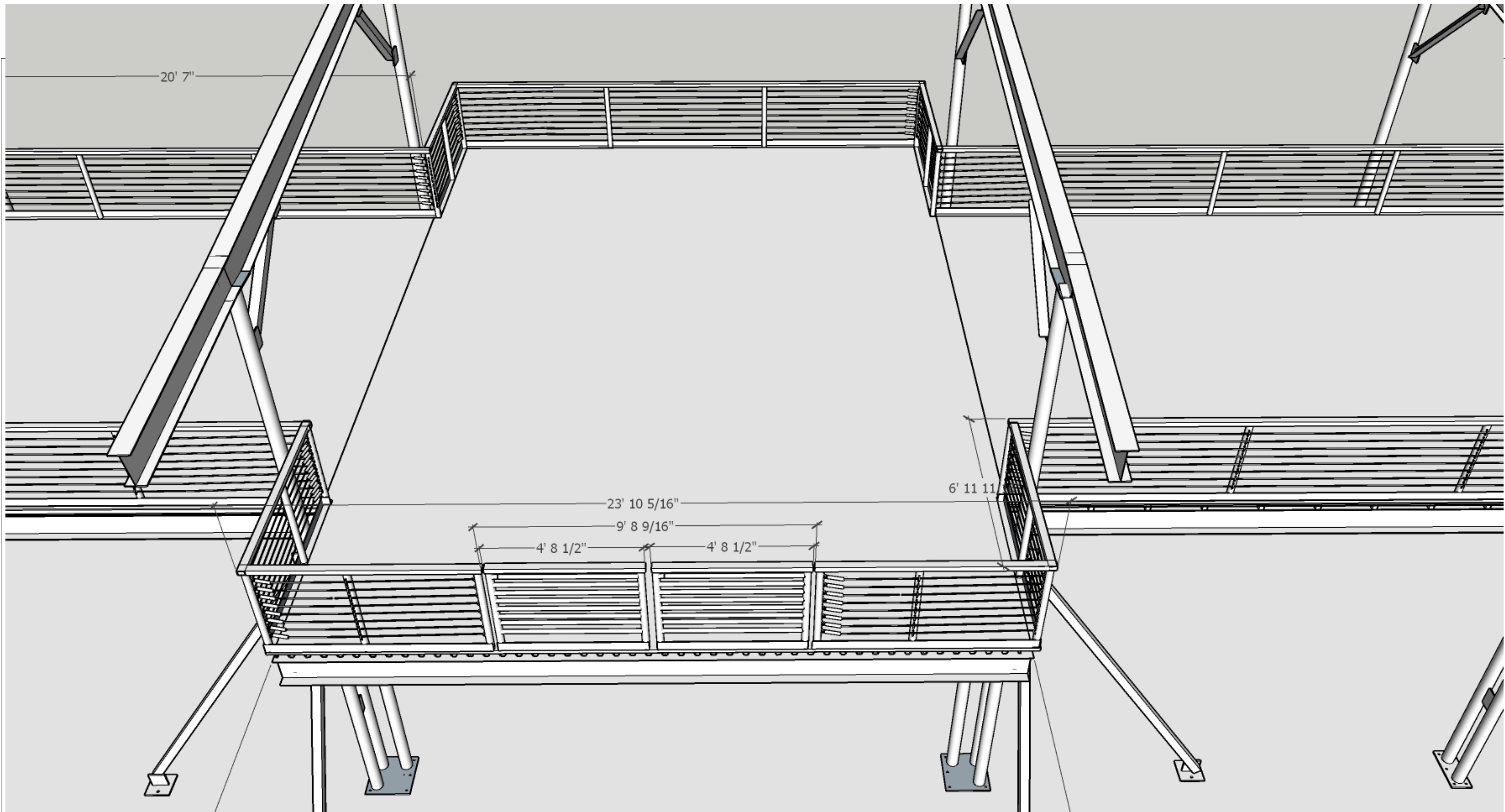

DOUBLE GATES FABRICATED WITH ROUND TUBING DIVIDERS. GATES TO SWING TO THE INSIDE.
 GATES TO HAVE LATCH AND DROP PIN.

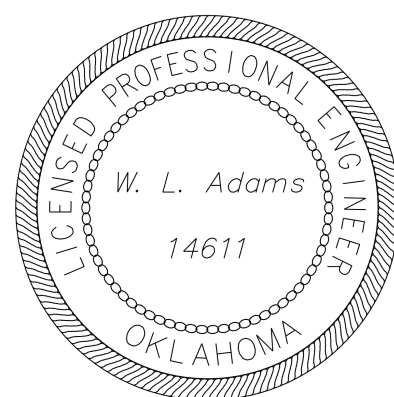

SHEET: 32



CHERRY PI ENGINEERING, LLC
 5105 W. 66TH ST. S. SUITE B
 TULSA, OK 74131
 918-205-0934

PROJECT: WILL ROGERS STAMPEDE ARENA
 VIP MEZZ. 2025
 DRAWING: GUARD RAIL GATE
 SHEET: 32 DATE: 07/18/2025 BY: WIN ADAMS

REAR STAIRS OPENING #A1

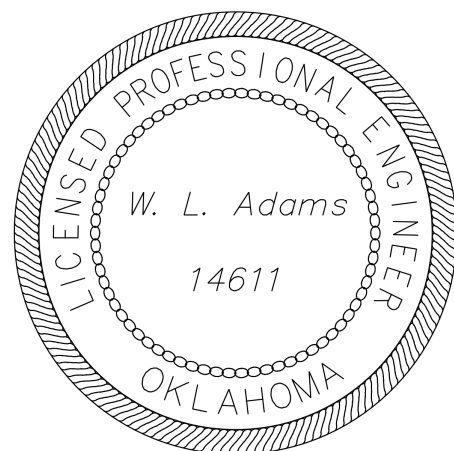
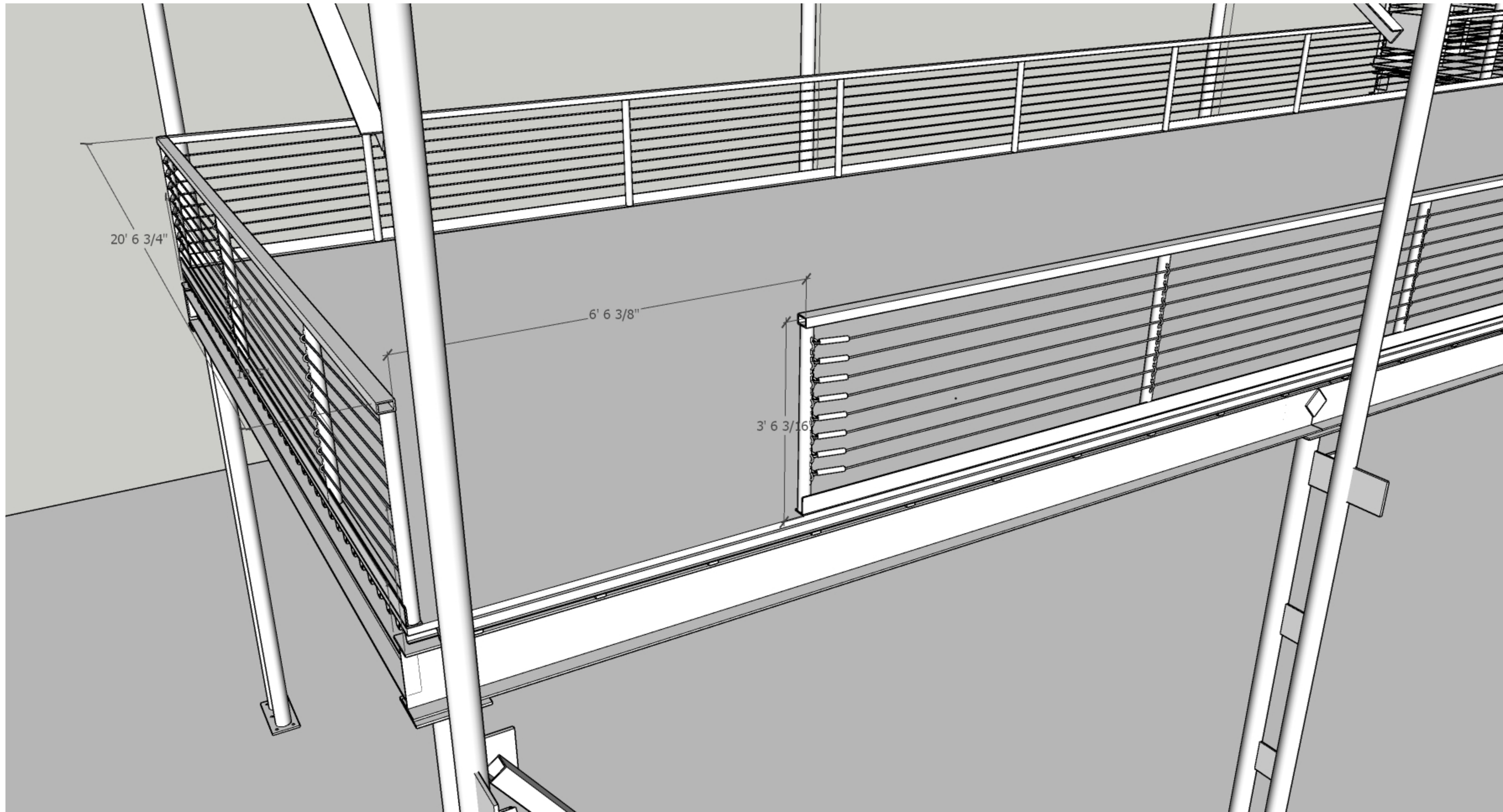

SHEET: 33

NORTH
→

CHERRY PI ENGINEERING, LLC
5105 W. 66TH ST. S. SUITE B
TULSA, OK 74131
918-205-0934

PROJECT: WILL ROGERS STAMPEDE ARENA
VIP MEZZ. 2025
DRAWING: GUARD RAIL OPENINGS
SHEET: 33 DATE: 07/18/2025 BY: WIN ADAMS

END STAIRS AND CHAIR LIFT OPENINGS A2 & A3

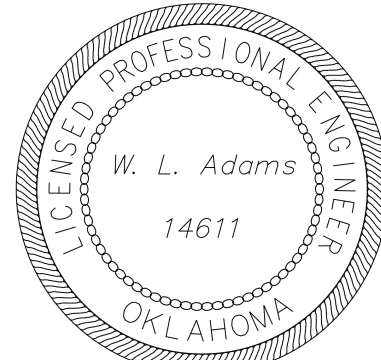
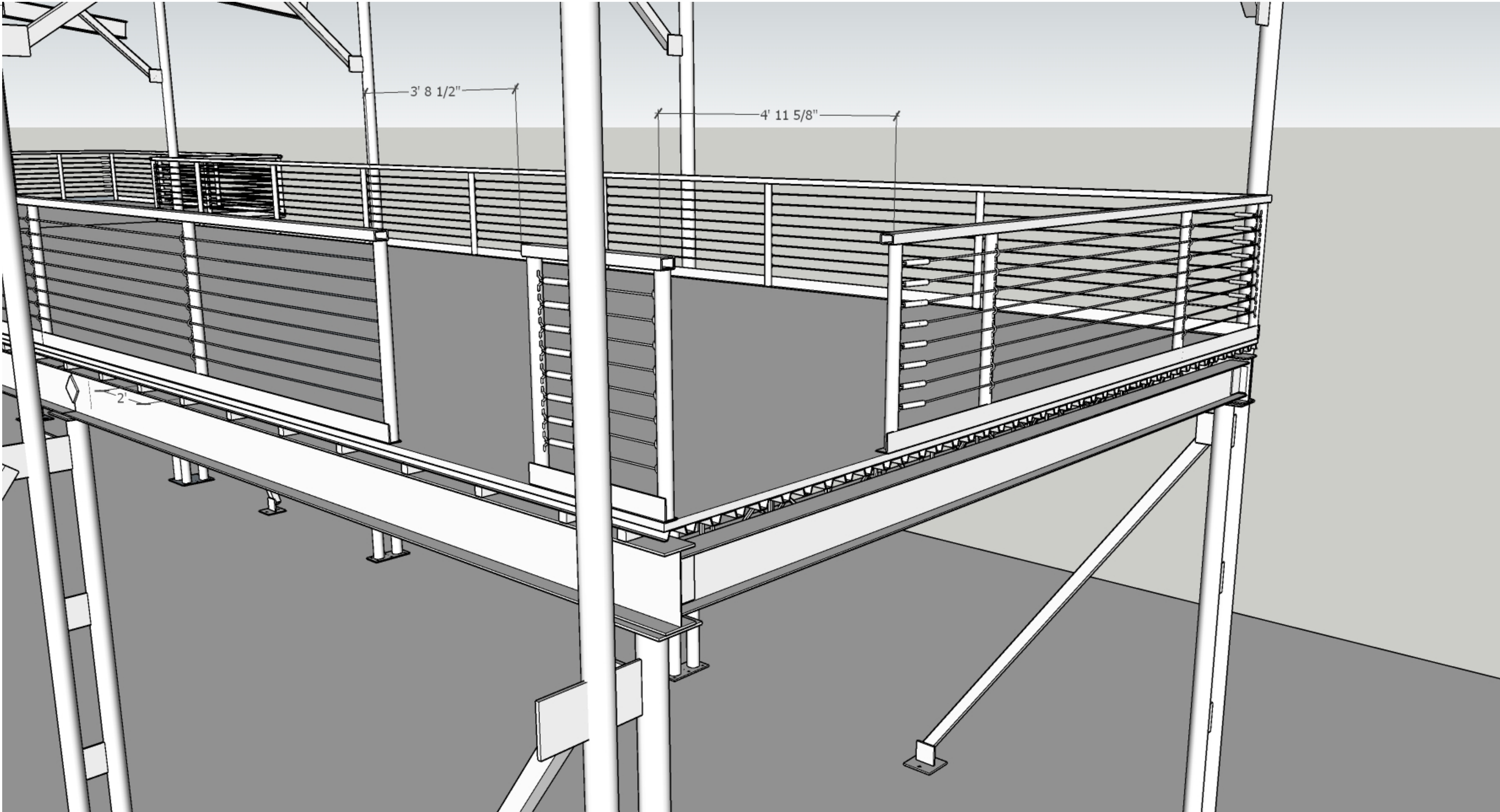

SHEET: 34



CHERRY PI ENGINEERING, LLC
 5105 W. 66TH ST. S. SUITE B
 TULSA, OK 74131
 918-205-0934

PROJECT: WILL ROGERS STAMPEDE ARENA
 VIP MEZZ. 2025
 DRAWING: GUARD RAIL OPENINGS
 SHEET: 34 DATE: 07/18/2025 BY: WIN ADAMS

ROOF PURLIN INSTALL

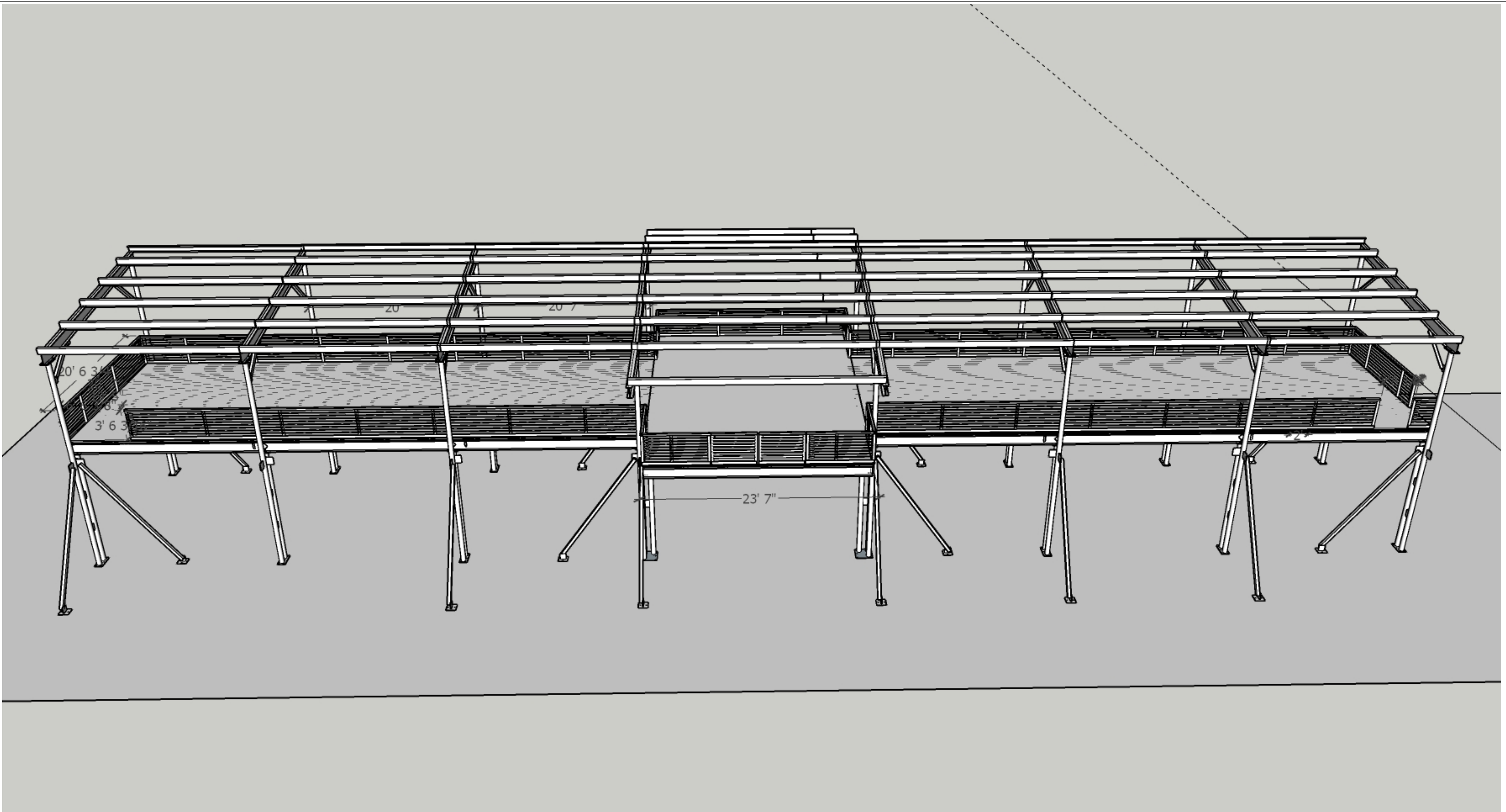

INSTALL ROOF PURLINS WITH 4 FT. NOMINAL SPACING. USE STANDARD METAL BUILDING PURLINS 8" HEIGHT. PROVIDE METAL PURLIN BRACKETS AND WELD BRACKETS TO ROOF BEAMS AS RECOMMENDED BY CLIP MANUFACTURER. BOLT PURLINS TO CLIPS PER METAL BUILDING STANDARDS. INSTALL BRACE ANGLES FROM PURLINS TO ROOF BEAMS. INSTALL WELD ON CLIPS TO BEAMS AND BOLT BRACE ANGLES TO THESE.

INSTALL PROPER EAVE STRUTS ON FRONT AND REAR BUILDING EDGE.

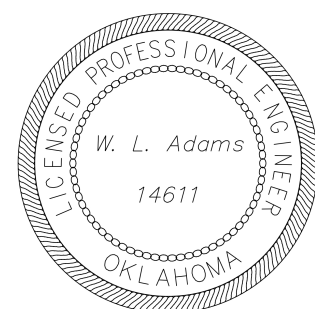

SHEET: 35

NORTH



CHERRY PI ENGINEERING, LLC
5105 W. 66TH ST. S. SUITE B
TULSA, OK 74131
918-205-0934

PROJECT: WILL ROGERS STAMPEDE ARENA
VIP MEZZ. 2025
DRAWING: ROOF PURLIN INSTALL
SHEET: 35 DATE: 07/18/2025 BY: WIN ADAMS

ROOF METAL PANEL NSTALL

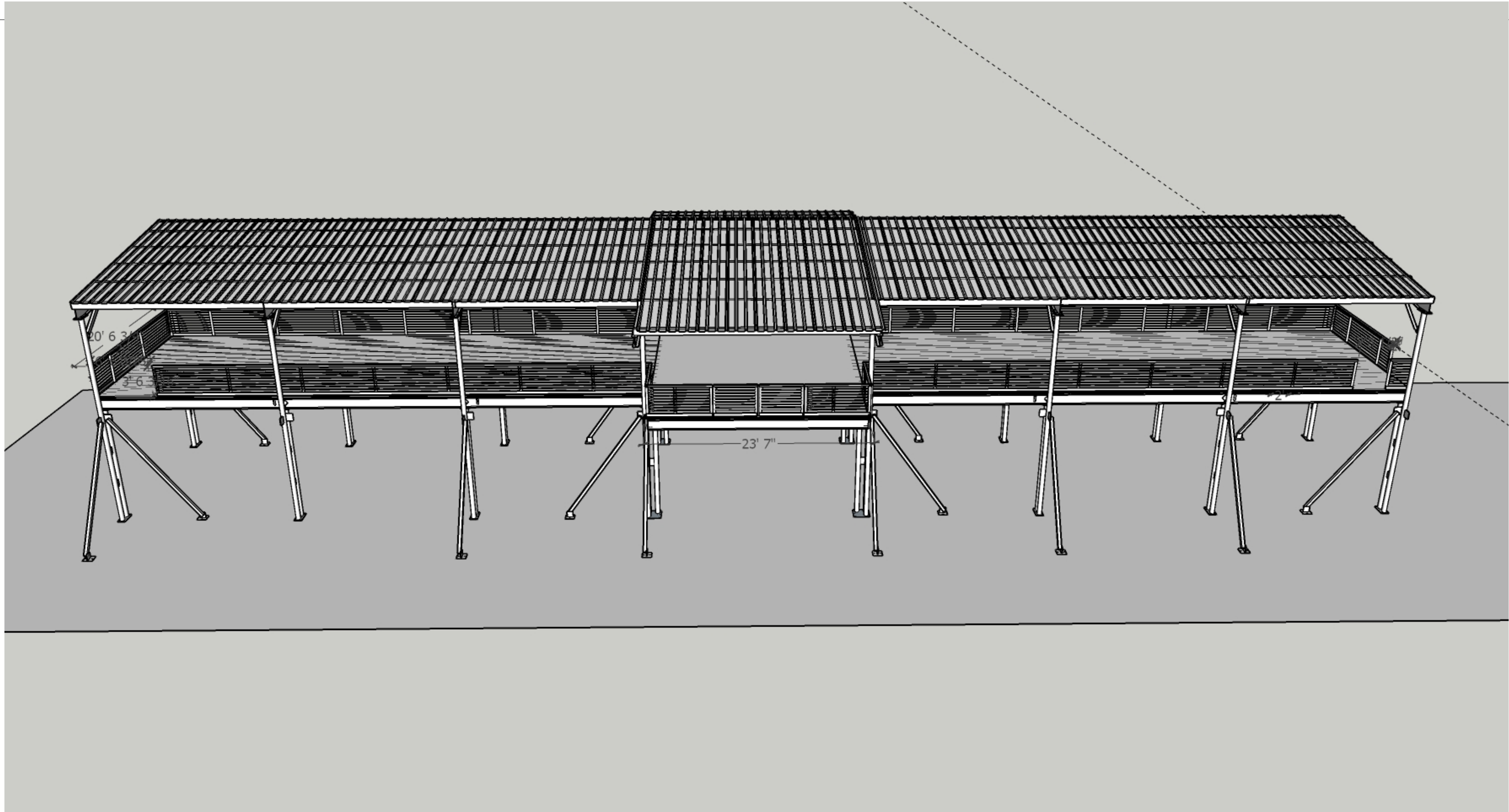

INSTALL METAL "R" PANEL ROOF . COLOR TO BE SELECTED BY THE OWNER
APPROXIMATELY 3,500 SQ. FT. OF ROOFING OF VARIOUS LENGTHS WILL BE REQUIRED

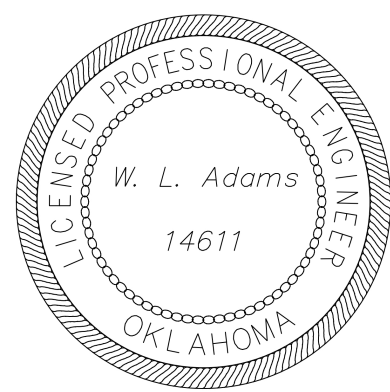

SHEET: 36

NORTH



CHERRY PI ENGINEERING, LLC
5105 W. 66TH ST. S. SUITE B
TULSA, OK 74131
918-205-0934

PROJECT: WILL ROGERS STAMPEDE ARENA
VIP MEZZ. 2025
DRAWING:ROOF SHEET INSTALL
SHEET: 36 DATE: 07/18/2025 BY: WIN ADAMS

MISC COMPONENTS

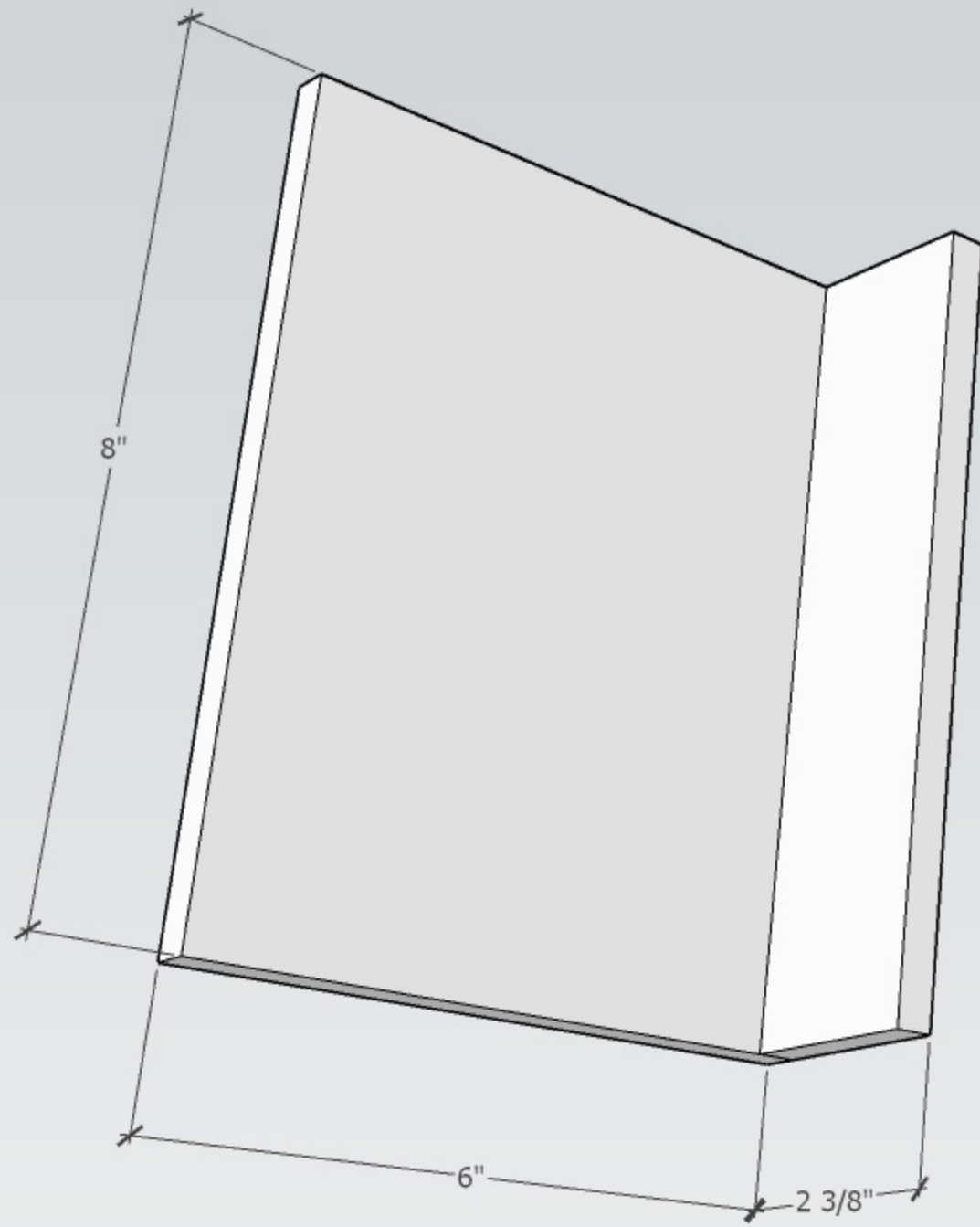

BCA01 CONNECTING ANGLE
6" X 2-3/8" X 8" X 3/8" PLATE
24 EA. REQ'D

SHEET: 37

CHERRY PI ENGINEERING, LLC
5105 W. 66TH ST. S. SUITE B
TULSA, OK 74131
918-205-0934

PROJECT: WILL ROGERS STAMPEDE ARENA
VIP MEZZ. 2025
DRAWING: MISC COMPONENTS
SHEET: 37 DATE: 07/18/2025 BY: WIN ADAMS

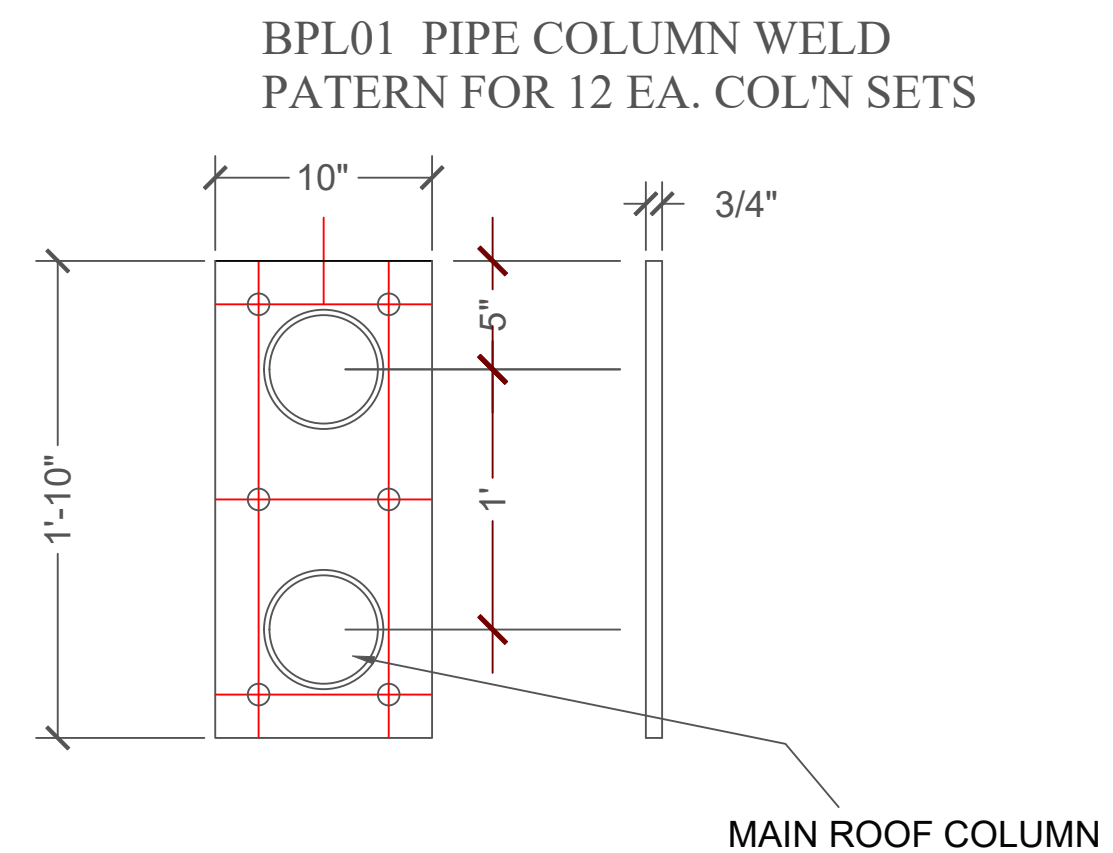
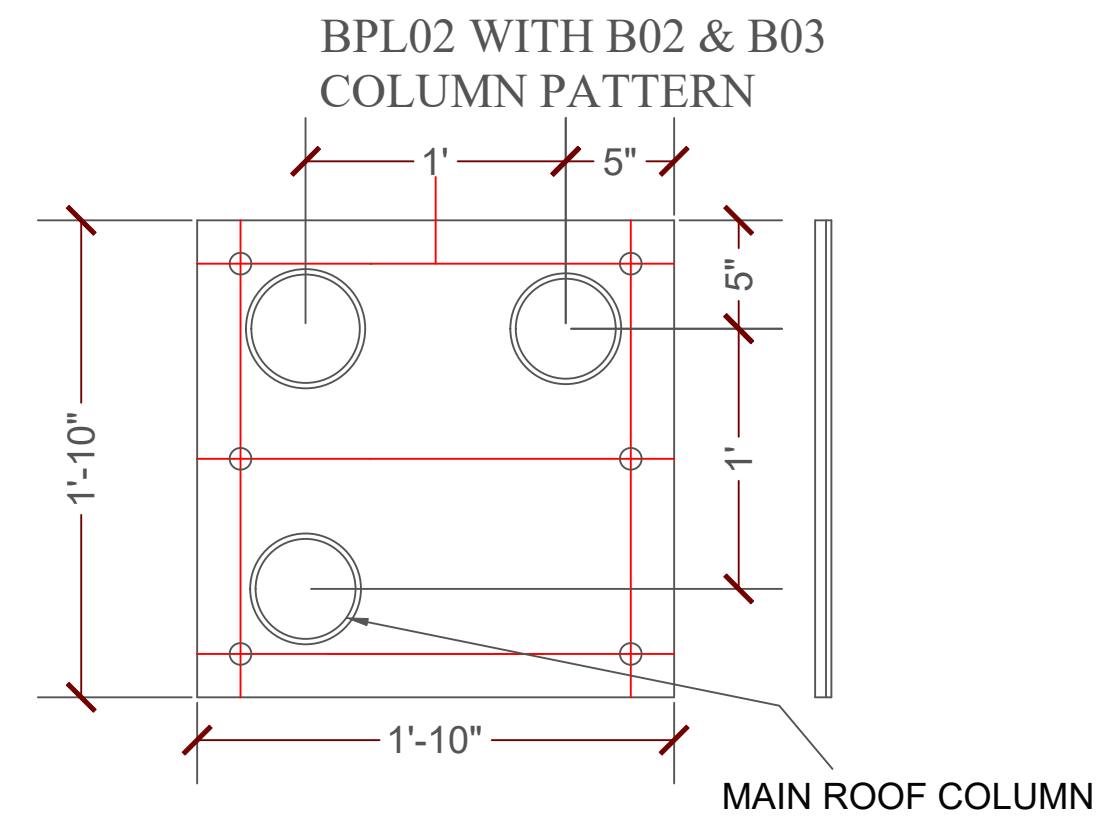
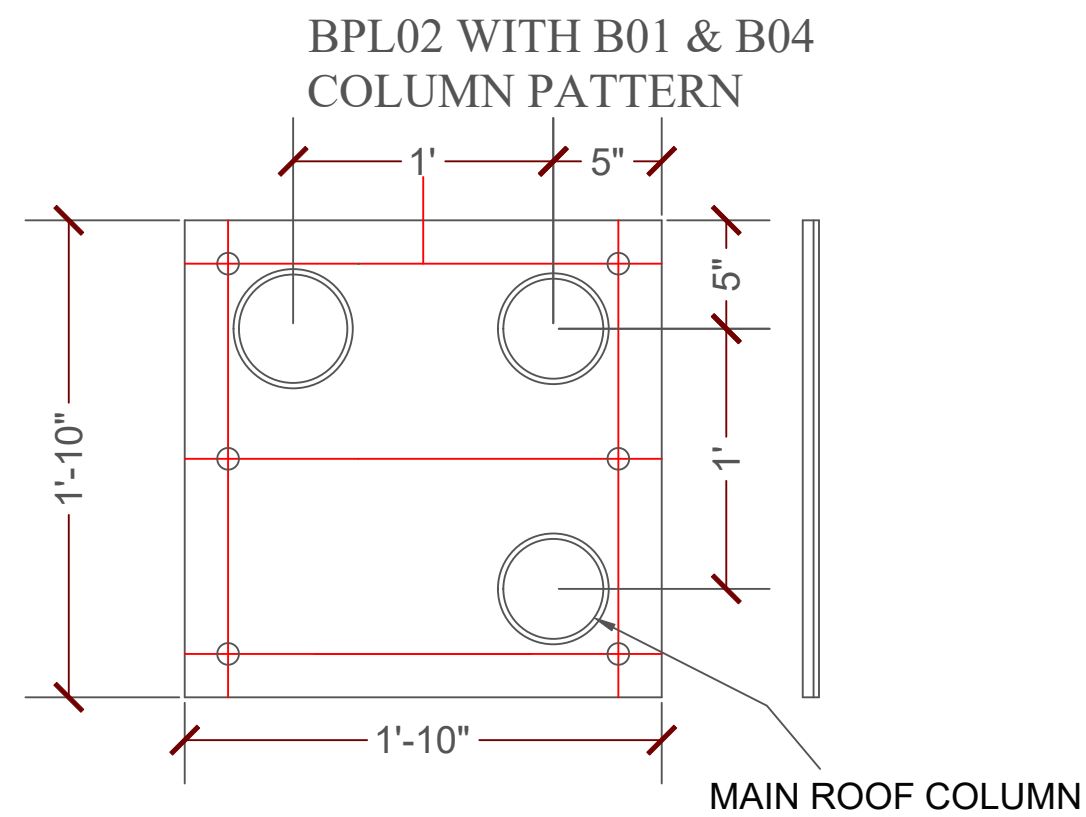

SHEET: 38

CHERRY PI ENGINEERING, LLC
5105 W. 66TH ST. S. SUITE B
TULSA, OK 74131
918-205-0934

PROJECT: WILL ROGERS STAMPEDE ARENA
VIP MEZZ. 2025
DRAWING: COLUMN WELD ASSEMBLIES
SHEET: 38 DATE: 07/18/2025 BY: WIN ADAMS

Will Rogers Stampede Arena VIP Mezzanine 2025

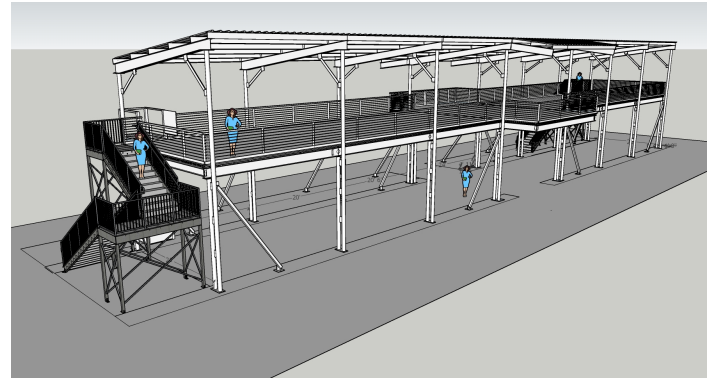
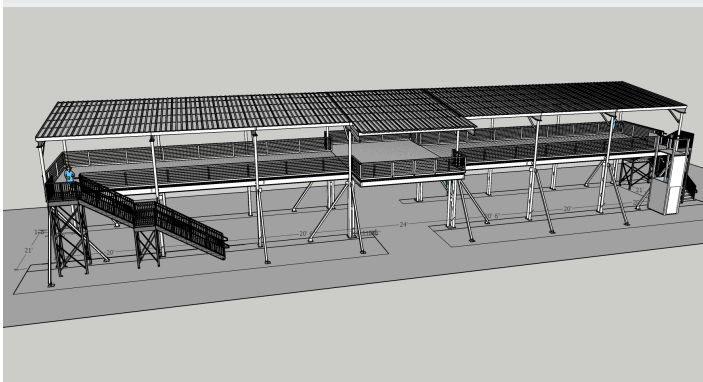

Engineering and Design
Cherry Pi Engineering LLC
5105 W. 66th St. S. Suite B
Tulsa, OK 74131
918-205-0934

Sean Wheeler, PE
Win Adams, PE

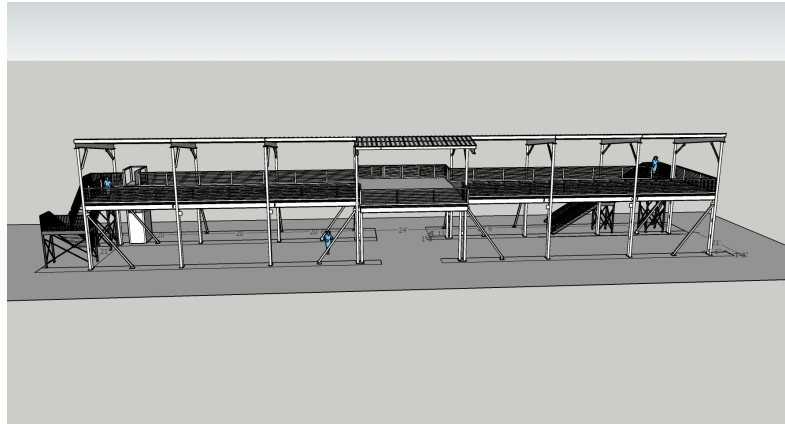

Will Rogers Stampede Arena VIP Mezzanine 2025

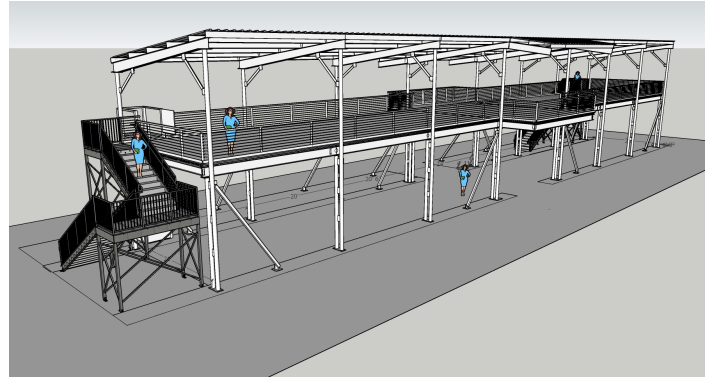
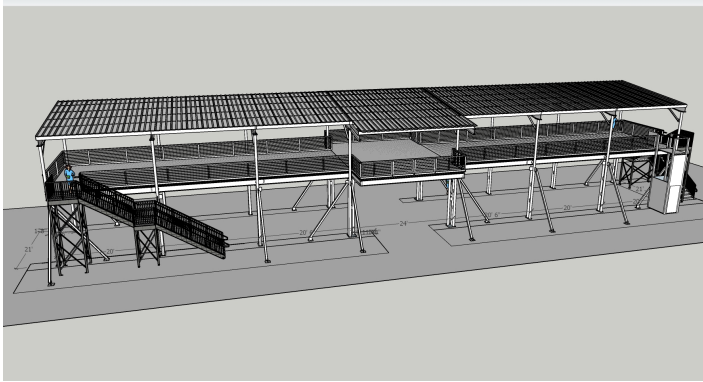

STAIR LOCATIONS

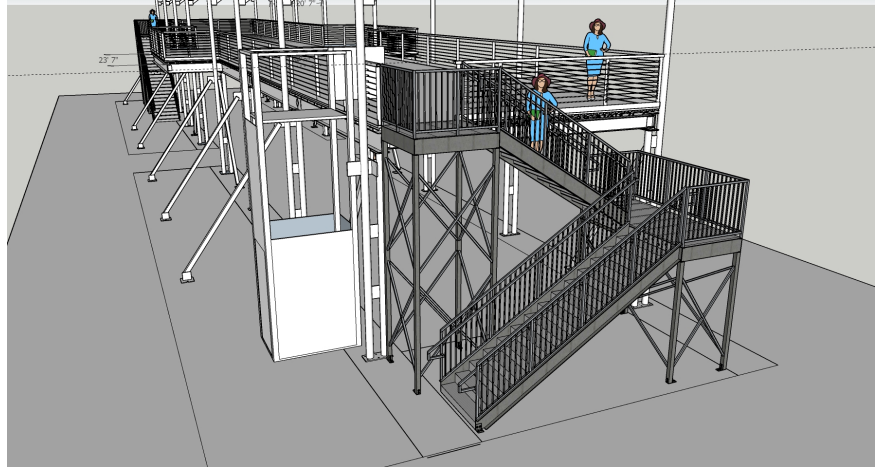

Engineering and Design
Cherry Pi Engineering LLC
5105 W. 66th St. S. Suite B
Tulsa, OK 74131
918-205-0934

Sean Wheeler, PE Win
Adams, PE

WPS--PDF-A01